



Item#: **50118**
LANDSCAPE LIGHTING
BRASS PACIFIC COVER COMPOSITE
IN-GROUND

The Pacific landscape light is a heavy duty in ground low voltage outdoor fixture with an adjustable socket for precise lighting.

FEATURES

- Tempered heat resistant glass
- SJTW 18# wire
- Silicone Wire Nuts are included

APPLICATION

Ideal for in ground landscape, pathway and accent lighting

ELECTRICAL

Supported Lamp Type	MR16
Voltage	12V
Base	GU5.3

LIGHTING PERFORMANCE

Beam Angle	Flood
Dimmable Lighting Control	

ENVIRONMENT

Suitable Location	WET
Ingress Protection Rating	IP68

LIFESPAN

Warranty (Years)	5
------------------	----------

CONSTRUCTION

Housing	Brass
Lens	Glass / Clear
Base / Power Supply	Hard Wired
Finish	Bronze

Specifications are subject to change without notice.

Item#: **50118**
LANDSCAPE LIGHTING

DIMENSIONS (Inches)	
Length (MOL)	5.5"
Width/Diameter (MOD)	5"
Weight (Lbs)	--

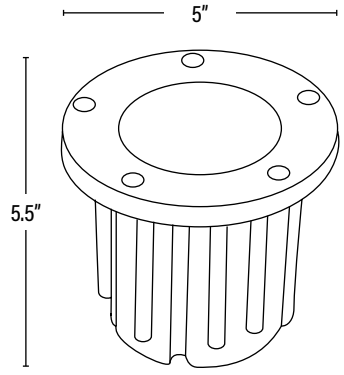

SUPPORTING DOCUMENTS (Grey = not available at this time.)	
Product Sheet	VIEW
Install Instructions	VIEW

PACKAGING		UPC	DIMENSIONS (LxWxH)	GROSS WEIGHT (Lbs)
Master Carton	20	10811768027911	--	--
Individual Box	1	811768027914	--	--
Country of Origin	China			
HS Tariff	9405.99.4090			

ORDERING		
ITEM#	DESCRIPTION	CASE
50118	BRASS PACIFIC COVER COMPOSITE IN-GROUND/MR16/12V/BRZ	20

ACCESSORIES		
ITEM#	DESCRIPTION	CASE
91784	LED 7WMR16/30K/35°/DIMM/12V/GU5.3 - ENERGY STAR® T20C	12
91785	LED 7WMR16/50K/35°/DIMM/12V/GU5.3 - ENERGY STAR® T20C	12
50145	LANDSCAPE TRANSFORMER/100W/12-15V/STAINLESS STEE	1
50146	LANDSCAPE TRANSFORMER/300W/12-15V/STAINLESS STEEL	1
50148	7 DAY PROGRAMMABLE TIMER FOR LANDSCAPE TRANSFORMER	1
50149	PLUG-IN PHOTO CELL FOR LANDSCAPE TRANSFORMER	1
50135	BLACK SILICONE WIRE NUT 20 PACK	20
82192	8/2 WIRE	Per Foot
82196	10/2 WIRE	Per Foot
82199	12/2 WIRE	Per Foot

REPLACEMENT PARTS		
ITEM#	DESCRIPTION	CASE
501188	REPLACEMENT LENS FOR ITEMS 50118/BRASS PACIFIC COVER IN-GROUND	1