



Item#: **55100**  
**LED 2X2 SPEC-SELECT™**  
**CENTER BASKET TROFFER RETROFIT**  
 INTEGRATED RETROFIT KITS FOR 2X2 LUMINAIRES

**FEATURES**

Spec-Select™ Troffers feature adjustable wattage and color temperature for the perfect balance of light in any application.

- Energy efficient
- No flickering

**APPLICATION**

Ideal for retrofitting inefficient fixtures in malls, hospitals, airports, offices, lobbies and other residential and commercial applications.

**ELECTRICAL**

Wattage	30W / 35W / 40W
Voltage	120-277V
Current	0.33-0.14A
Power Factor	0.9
Total Harmonic Distortion (THD)	10

**LIGHTING PERFORMANCE**

Lumens	3780 / 4410 / 5040
Lumens Per Watt (LPW)	126
Color Temperature (CCT)	3500K / 4100K / 5000K
Color Rendering (CRI)	82
R9 (Red Value)	--
R13 (Skin Tones)	--
Beam Angle	100°
Light Distribution	Type VS
BUG Rating (Backlight, Uplight, and Glare)	--
Dimmable Lighting Control	<i>Dimmable</i> 0-10V, Range 10% - 100%

**ENVIRONMENT**

Operating Temperature	-4 ~ 122°F
Suitable Location	<b>DAMP</b>
Ingress Protection Rating	IP40

**LIFESPAN**

Average Life (Hours)	50,000
Warranty (Years)	<b>5</b>

**COMPONENTS**

LED Light Source	--
Driver	--

**CONSTRUCTION**

Housing	Aluminum
Lens	Frosted
Base / Power Supply	Hard Wired
Finish	White

**QUALIFICATIONS**

Pending

*Published lumens on LED products are approximate and may vary slightly. - Specifications are subject to change without notice.*

Item#: **55100**  
**LED 2X2 SPEC-SELECT™ CENTER BASKET TROFFER RETROFIT**



ITEM INFORMATION

**DIMENSIONS** (Inches)

Length	23.8"
Width	23.9"
Height	3.1"
Net Weight (Lbs)	8.7

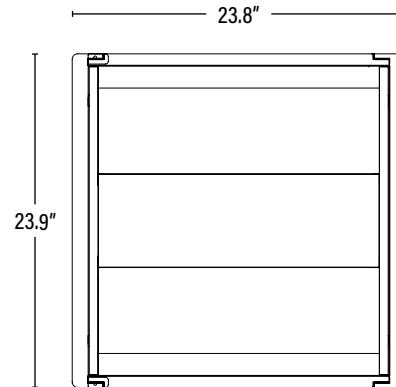

**SUPPORTING DOCUMENTS** (Grey = not available at this time.)

Product Sheet	VIEW
Install Instructions	VIEW
IES Download from Web Item	VIEW
LM79	VIEW
LM80	VIEW

PACKAGING	UPC	DIMENSIONS (LxWxH)	GROSS WEIGHT (Lbs)
Master Carton	1	--	--
Country of Origin	China		
HS Tariff	9405.10.6020		

**ORDERING**

ITEM#	DESCRIPTION	CASE
55100	LED 2X2 SPEC-SELECT™ CENTER BASKET TROFFER RETROFIT/30-35-40W/35-50K/DIMM/120-277V	1

**ACCESSORIES**

55390	EMERGENCY PACK FOR LED FIXTURE 8W/90 MIN- SPLIT TYPE/L - T20C	10
55391	EMERGENCY PACK FOR LED FIXTURE 16W/90 MIN- SPLIT TYPE/L - T20C	10
55392	EMERGENCY PACK FOR LED FIXTURE 25W/90 MIN- SPLIT TYPE/L - T20C	10

**REPLACEMENT PARTS**

--	REPLACEMENT LED DRIVER	1
----	------------------------	---

**ADDITIONAL INFORMATION:**

- Default settings; 40W, 5000K.
- The color temperature and wattage may be adjusted by two slide switches integrated into the driver. The color temperature and wattage should be selected prior to installation.

