

LED EMERGENCY PACK

INSTALL INSTRUCTIONS



PLEASE FIND A QUALIFIED ELECTRICIAN FOR INSTALLATION. Please read the instructions before you install and use with the luminaire.

WARNING, CAUTIONS AND OPERATING INSTRUCTIONS

- To reduce the risk of death, personal injury or property damage from fire, electric shock, falling parts, cuts/abrasions, and other hazards read all warnings and instructions included with and on the fixture box and all fixture labels.
- Before installing, servicing, or performing routine maintenance upon this equipment, follow these general precautions.
- Commercial installation, service and maintenance should be performed by a qualified licensed electrician.
- For The installation: If you are unsure about the installation or maintenance, consult a qualified licensed electrician and check your local electrical code.
- To prevent wiring damage or abrasion, do not expose wiring to edges of sheet metal or other sharp objects.
- Do not make or alter any open holes in an enclosure of wiring or electrical components during installation.

WARNING: RISK OF FIRE OR ELECTRICAL SHOCK

- Turn off electrical power at fuse or circuit breaker box before wiring fixture to the power supply.
- Turn off the power when you perform any maintenance.
- Verify that supply voltage is correct by comparing it with the luminaire label information.
- Make all electrical and grounded connections in accordance with the National Electrical Code and any applicable local code requirements.
- All wiring connections should be capped with UL approved wire connectors.

CAUTION: RISK OF INJURY

- An un-switched AC power source of 120V AC to 277V AC is required.
- This device is designed for use in fixtures listed for dry and damp locations.
- Do not let power supply cords touch hot surfaces.
- Do not mount near gas or electric heaters.
- Battery is rechargeable LiFePO4 type and must be recycled or disposed of properly.
- Do not use this emergency driver with accessory equipment other than recommended by manufacturer. Failure to follow this may cause an unsafe condition. Servicing should only be performed by qualified service personnel.
- Do not use this emergency driver for other than intended use. Equipment should be mounted in locations and at heights where it will not readily be subjected to tampering by unauthorized personnel.

! WARNING - TURN OF POWER SUPPLY FROM MAIN CIRCUIT BREAKER BEFORE INSTALLING OR SERVICING.

WIRING DIAGRAM (AND FOR EMERGENCY ONLY)

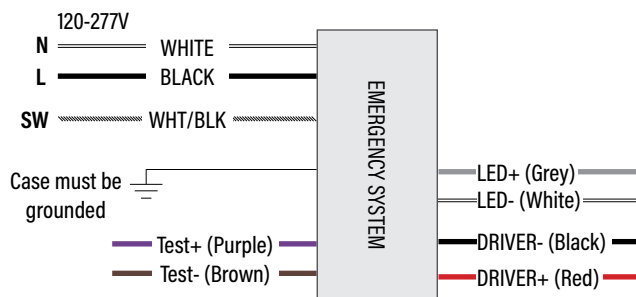

WIRE	LENGTH (in)
N (White)	29.5"
L (Black)	
SW (White/Black)	
Test+ (Purple)	32.2"
Test- (Brown)	
LED+ (Grey)	
LED- (White)	
Driver+ (Red)	
Driver- (Black)	

LED EMERGENCY PACK

INSTALL INSTRUCTIONS



TYPICAL WIRING DIAGRAM

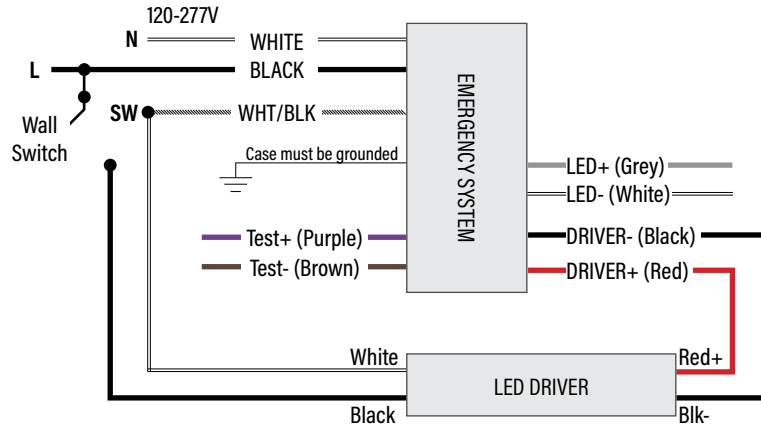

PROGRAM SWITCH

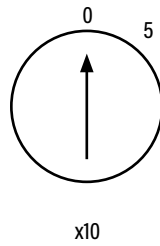
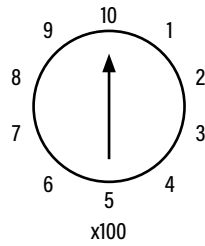

Programmable Constant Current

- Preset by factory
- Adjust it by yourself

Adjustable Output Current

- 10 ranges
- 50mA per scale

EMERGENCY BATTERY BACK UP MOUNTING BRACKET

Mounting bracket is required when using the emergency battery. *(Brackets are sold separately.)*

