

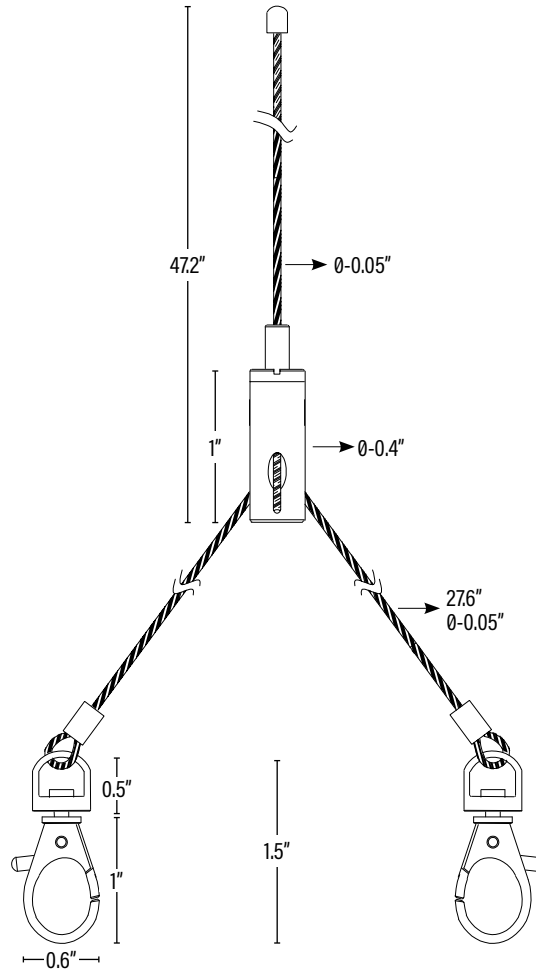

Item#: **55324**
2x2 or 2x4 SUSPENDED CABLE KIT
 FOR LED PANELS

APPLICATION

For use with 2x2 or 2x4 LED panels.



DIMENSIONS (Inches)

Length	See Line Drawing
Cable Diameter	0.05"
Height	See Line Drawing
Weight (Lbs)	--

Line drawings may not be to scale and are for general reference only.

PACKAGING

		UPC	DIMENSIONS (LxWxH)	GROSS WEIGHT (Lbs)
Master Carton	1	854432004545	--	--
Country of Origin	China			
HS Tariff	9405.99.4090			

ORDERING

ITEM#	DESCRIPTION	CASE
55324	2X2 OR 2X4 SUSPENDED CABLE MOUNTING KIT FOR LED PANEL - SUPERIOR LIFE®	1