

Item#: **55356**
MOUNTING BRACKET
FOR EMERGENCY BATTERY

APPLICATION

For use with a 1X4 LED V5 Panel and Emergency Pack

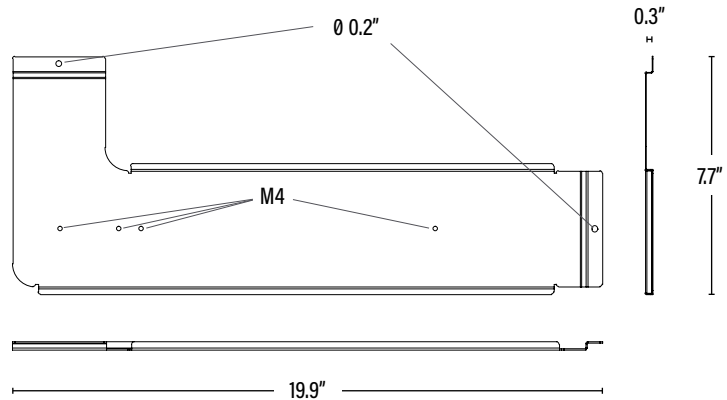

DIMENSIONS (Inches)

Length	19.9"
Width	0.3"
Height	7.7"

PACKAGING

		UPC	DIMENSIONS (LxWxH)	GROSS WEIGHT (Lbs)
Master Carton	60	10811768027140	--	--
Inner Carton	10	20811768027147	--	--
Individual Item	1	811768027143	--	--
Country of Origin	China			
HS Tariff	9405.99.4090			

ORDERING

ITEM#	DESCRIPTION	CASE
55356	MOUNTING BRACKET FOR EMERGENCY BATTERY FOR 1X4 LED EDGE-LIT PANEL	60