

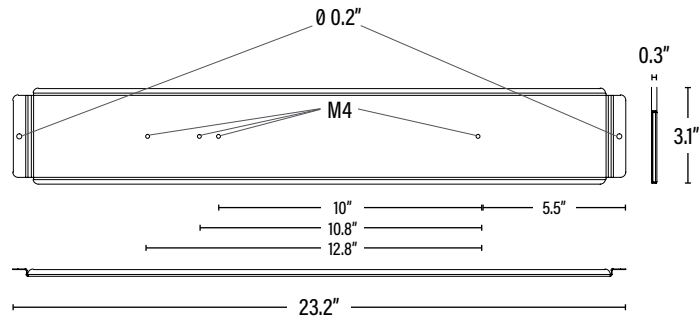

Item#: **55357**
MOUNTING BRACKET
FOR EMERGENCY BATTERY

APPLICATION

For use with a 2X2 or 2X4 LED V5 Panel and
Emergency Pack



DIMENSIONS (Inches)

| | |
|--------|-------|
| Length | 23.2" |
| Width | 0.3" |
| Height | 3.1" |

PACKAGING

| | | UPC | DIMENSIONS (LxWxH) | GROSS WEIGHT (Lbs) |
|-------------------|--------------|----------------|--------------------|--------------------|
| Master Carton | 60 | 10811768027461 | -- | -- |
| Inner Carton | 10 | 20811768027468 | -- | -- |
| Individual Item | 1 | 811768027464 | -- | -- |
| Country of Origin | China | | | |
| HS Tariff | 9405.99.4090 | | | |

ORDERING

| ITEM# | DESCRIPTION | CASE |
|-------|--|------|
| 55357 | MOUNTING BRACKET FOR EMERGENCY BATTERY FOR 2X2 OR 2X4 EDGE-LIT LED PANEL | 60 |