



Item#: **55393**
MOUNTING BRACKET
FOR EMERGENCY BATTERY

APPLICATION

For use with Emergency Pack, on select 2X2 or 2X4 Backlit Panels.

SUPPORTING DOCUMENTS (Grey = not available at this time.)

Product Sheet	VIEW
Install Instructions	VIEW

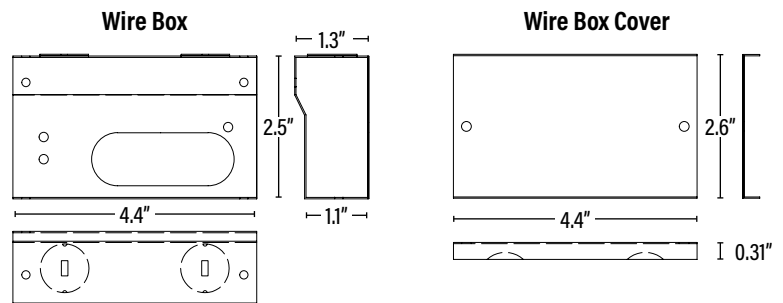
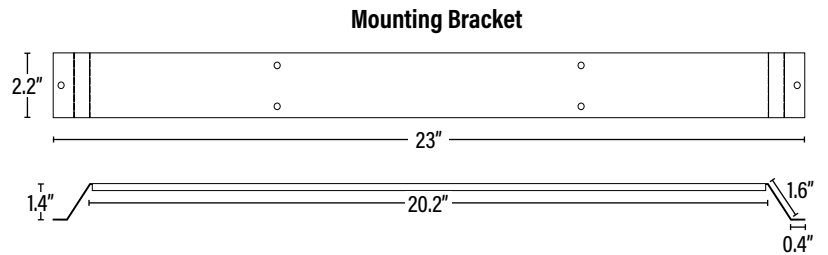

PACKAGING

		UPC	DIMENSIONS (LxWxH)	GROSS WEIGHT (Lbs)
Master Carton	60	10854432004115	--	--
Individual Item	1	854432004118	23.6" x 3" x 2"	1.2
Country of Origin	China			
HS Tariff	9405.99.4090			

ORDERING

ITEM#	DESCRIPTION	CASE
55393	MOUNTING BRACKET + WIRE BOXES FOR EMERGENCY PACK, ON SELECT 2X2 OR 2X4 BACKLIT PANELS	20

KIT INCLUDES:

- 1 - Mounting Bracket
- 2 - Wire Boxes
- 2 - Wire box covers
- 8 - Screws

COMPATIBLE BACKLIT PANELS with a production month of June 2020 (20/06) or later. Older versions will be missing the knockout on one end.