



Item#: **55661**
LED 1X4 BACK-LIT PANEL
1X4 LUMINARIES FOR AMBIENT LIGHTING OF
INTERIOR COMMERCIAL SPACES

FEATURES

- High Efficiency, Energy Saving
- Up to 36% Savings vs. T8 Fluorescent
- Low glare, bright consistent lighting
- For covered ceilings only
- Earthquake proof hooks included

APPLICATION

Ideal for offices, conference rooms, hospitals, lobbies, hotels, classrooms, workshops, cafeterias and other common areas.

ELECTRICAL

Wattage	40W
Voltage	120-277V
Current	0.33-0.14A
Power Factor	0.9
Total Harmonic Distortion (THD)	10

LIGHTING PERFORMANCE

Lumens	4400
Lumens Per Watt (LPW)	110
Color Temperature (CCT)	4000K
Color Rendering (CRI)	82
R9 (Red Value)	--
R13 (Skin Tones)	--
Beam Angle	120°
Light Distribution	Type VS
BUG Rating (Backlight, Uplight, and Glare)	--
Dimmable Lighting Control	<i>Dimmable</i> 0-10V, Range 10% - 100%

ENVIRONMENT

Operating Temperature	-4° ~ 113°F
Suitable Location	DAMP
Ingress Protection Rating	IP40

LIFESPAN

Average Life (Hours)	50,000
Warranty (Years)	5

COMPONENTS

LED Light Source	--
Driver	--

CONSTRUCTION

Housing	Aluminum
Lens	Frosted
Base / Power Supply	Hard Wired
Finish	White

QUALIFICATIONS

Pending

Published lumens on LED products are approximate and may vary slightly. - Specifications are subject to change without notice.

Item#: **55661**
LED 1X4 BACK-LIT PANEL



ITEM INFORMATION

DIMENSIONS (Inches)

Length	47.8"
Width	11.9"
Height	1.6"
Weight (Lbs)	--

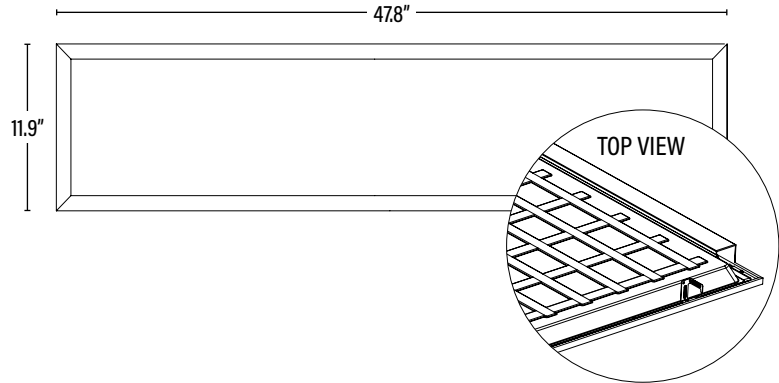

SUPPORTING DOCUMENTS (Grey = not available at this time.)

Product Sheet	VIEW
Install Instructions	VIEW
IES Download from Web Item	VIEW
LM79	VIEW
LM80	VIEW

PACKAGING

		UPC	DIMENSIONS (LxWxH)	GROSS WEIGHT (Lbs)
Master Carton	2	--	--	--
Individual Box	1	--	N/A	--
Country of Origin	China			
HS Tariff	9405.10.6020			

ORDERING

ITEM#	DESCRIPTION	CASE
55661	LED 1X4 PANEL/BLP/40W/40K/DIMM/120-277V	2

ACCESSORIES

55127	1X4 FLANGE KIT FOR PANEL & TROFFER/WHT	1
55530	1X4 SURFACE MOUNTED KIT FOR LED BACK-LIT PANEL/WHT	1
55445	SUSPENDED CABLE MOUNTING KIT FOR LED PANEL	100
55394	EMERGENCY PACK FOR LED PANEL 8W/90 MIN	10
55395	EMERGENCY PACK MOUNTING BRACKET AND WIRE BOXES FOR LED 1X4 BACK-LIT PANEL - 55394	20

REPLACEMENT PARTS

--	REPLACEMENT LED DRIVER	1
----	------------------------	---

ADDITIONAL INFORMATION:

Family Item(s): 55660/3500K - 55662/5000K