

## Item **55750-8WEM**

### **LED 1X4 SPEC-SELECT™ BACK-LIT PANEL**

**1X4 LUMINARIES FOR AMBIENT LIGHTING OF  
INTERIOR COMMERCIAL SPACES**

#### **FEATURES**

Spec-Select™ Backlit energy-efficient LED panels are like 9 fixtures in 1, and can provide the perfect balance of light in any application.

- Adjustable Wattage (3 settings)
- Adjustable Color (3 settings)
- Integrated Sensor option (ISO). Plug-in Motion + Daylight Sensor sold separately.
- 8W emergency battery pre-installed.

#### **APPLICATION**

Ideal for retrofitting inefficient fixtures in malls, hospitals, airports, offices, lobbies and other residential and commercial applications.

#### **ELECTRICAL**

Wattage	20W / 25W / 30W
Voltage	120-277V
Current	0.25-0.10A
Power Factor	0.9
Total Harmonic Distortion (THD)	10

#### **LIGHTING PERFORMANCE**

Lumens	2500 / 3125 / 3750
Lumens Per Watt (LPW)	125
Color Temperature (CCT)	3500K / 4100K / 5000K
Color Rendering (CRI)	83
R9 (Red Value)	7
Beam Angle	120°
Light Distribution	Type VS
BUG Rating (Backlight, Uplight, and Glare)	B2 - U1 - G1
Dimmable Lighting Control	From optional sensor, or customer 0-10V controls

#### **ENVIRONMENT**

Operating Temperature	-4° ~ 113°F
Suitable Location	<b>DAMP</b>
Ingress Protection Rating	IP40

#### **LIFESPAN**

Average Life (Hours)	50,000
Warranty (Years)	<b>5</b>

#### **COMPONENTS**

LED Light Source	Bridgelux 2835
Driver	SIF30-I0800
Emergency Battery	55703
Sensor Socket	12VDC AUX.

#### **CONSTRUCTION**

Housing	Aluminum
Lens	Frosted
Base / Power Supply	Hard Wired
Finish	White

#### **QUALIFICATIONS**

Pending

*Published lumens on LED products are approximate and may vary slightly. - Specifications are subject to change without notice.*

Item#: **55750-8WEM**  
**LED 1X4 SPEC-SELECT™ BACK-LIT PANEL**



ITEM INFORMATION

**DIMENSIONS** (Inches)

Length	47.6"
Width	11.9"
Height	1.6"
Weight (Lbs)	--

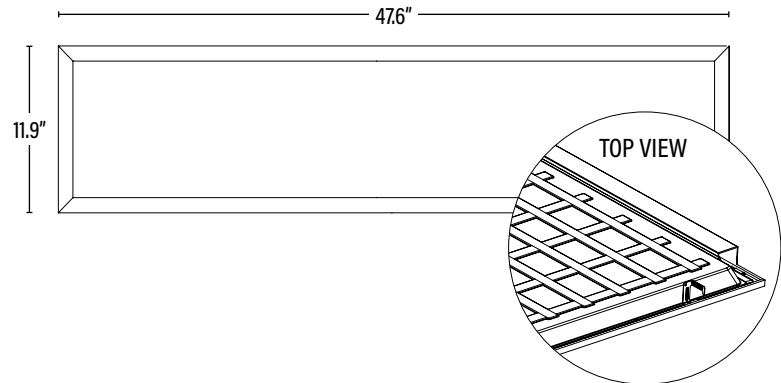

**SUPPORTING DOCUMENTS** (Grey = not available at this time.)

Product Sheet	VIEW
Install Instructions	VIEW
Emergency Battery	VIEW
IES Download from Web Item	VIEW
LM79	VIEW
LM80	VIEW

**PACKAGING**

		UPC	DIMENSIONS (LxWxH)	GROSS WEIGHT (Lbs)
Master Carton	2	10811768024828	49.3" x 3.8" x 13.7"	--
Individual Item	1	811768024821	N/A	--
Country of Origin	China			
HS Tariff	9405.11.6020			

**ORDERING**

ITEM#	DESCRIPTION	CASE
55750-8WEM	LED 1X4 SPEC-SELECT™ PANEL/BLP/20-25-30W/35-50K/DIMM/ISO/120-277V/8W EMB	2

**ACCESSORIES**

54880	BI-LEVEL AND DAYLIGHT PIR SENSOR FOR LED PANEL/UP TO 12FT HEIGHT • 12-24V DC	100
55127	1X4 FLANGE KIT FOR PANEL & TROFFER/WHT	1
55530	1X4 SURFACE MOUNTED KIT FOR LED BACK-LIT PANEL/WHT	1
55445	5FT SUSPENDED CABLE MOUNTING KIT FOR LED PANEL	100
55446	10FT SUSPENDED CABLE MOUNTING KIT FOR LED PANEL	100

**REPLACEMENT PARTS**

55703	EMERGENCY PACK FOR LED PANEL 8W/90 MIN	10
SIF30-I0800	REPLACEMENT LED DRIVER	1

**ADDITIONAL INFORMATION:**

- Default settings; 20W, 5000K.
- The color temperature and wattage may be adjusted by two slide switches integrated into the driver, selection should be made prior to installation.

