

Item **55751-8WEM**
LED 2X2 SPEC-SELECT™
BACK-LIT PANEL

**2X2 LUMINARIES FOR AMBIENT LIGHTING OF
INTERIOR COMMERCIAL SPACES**

FEATURES

Spec-Select™ Backlit energy-efficient LED panels are like 9 fixtures in 1, and can provide the perfect balance of light in any application.

- Adjustable Wattage (3 settings)
- Adjustable Color (3 settings)
- Integrated Sensor option (ISO). Plug-in Motion + Daylight Sensor sold separately.
- 8W emergency battery pre-installed.

APPLICATION

Ideal for retrofitting inefficient fixtures in malls, hospitals, airports, offices, lobbies and other residential and commercial applications.

ELECTRICAL

Wattage	20W / 25W / 30W
Voltage	120-277V
Current	0.25-0.10A
Power Factor	0.9
Total Harmonic Distortion (THD)	10

LIGHTING PERFORMANCE

Lumens	2500 / 3125 / 3750
Lumens Per Watt (LPW)	125
Color Temperature (CCT)	3500K / 4100K / 5000K
Color Rendering (CRI)	83
R9 (Red Value)	7
Beam Angle	120°
Light Distribution	Type VS
BUG Rating (Backlight, Uplight, and Glare)	B2 - U1 - G1
Dimmable Lighting Control	From optional sensor, or customer 0-10V controls

ENVIRONMENT

Operating Temperature	-4° ~ 113°F
Suitable Location	DAMP
Ingress Protection Rating	IP40

LIFESPAN

Average Life (Hours)	50,000
Warranty (Years)	5

COMPONENTS

LED Light Source	Bridgelux 2835
Driver	SIF30-I0800
Emergency Battery	55703
Sensor Socket	12VDC AUX.

CONSTRUCTION

Housing	Aluminum
Lens	Frosted
Base / Power Supply	Hard Wired
Finish	White

QUALIFICATIONS

Pending

Published lumens on LED products are approximate and may vary slightly. - Specifications are subject to change without notice.

Item#: **55751-8WEM**
LED 2X2 SPEC-SELECT™ BACK-LIT PANEL



ITEM INFORMATION

DIMENSIONS (Inches)

Length	23.8"
Width	23.8"
Height	1.6"
Weight (Lbs)	--

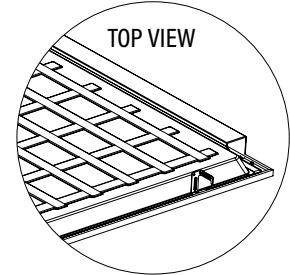
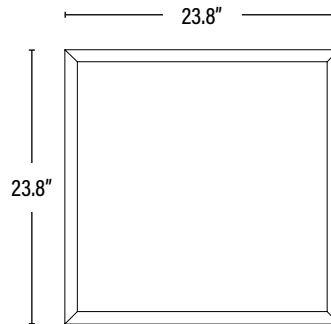

SUPPORTING DOCUMENTS (Grey = not available at this time.)

Product Sheet	VIEW
Install Instructions	VIEW
Emergency Battery	VIEW
IES Download from Web Item	VIEW
LM79	VIEW
LM80	VIEW

PACKAGING

		UPC	DIMENSIONS (LxWxH)	GROSS WEIGHT (Lbs)
Master Carton	2	10811768025375	25.3" x 3.8" x 25.6"	--
Individual Item	1	811768025378	N/A	--
Country of Origin	China			
HS Tariff	9405.11.6020			

ORDERING

ITEM#	DESCRIPTION	CASE
55751-8WEM	LED 2X2 SPEC-SELECT™ PANEL/BLP/20-25-30W/35-50K/DIMM/ISO/120-277V/8W EMB	2

ACCESSORIES

54880	BI-LEVEL AND DAYLIGHT PIR SENSOR FOR LED PANEL/UP TO 12FT HEIGHT • 12-24V DC	100
55128	2X2 FLANGE KIT FOR PANEL & TROFFER/WHT	1
55531	2X2 SURFACE MOUNTED KIT FOR LED BACK-LIT PANEL/WHT	1
55445	5FT SUSPENDED CABLE MOUNTING KIT FOR LED PANEL	100
55446	10FT SUSPENDED CABLE MOUNTING KIT FOR LED PANEL	100

REPLACEMENT PARTS

55703	EMERGENCY PACK FOR LED PANEL 8W/90 MIN	10
SIF30-I0800	REPLACEMENT LED DRIVER	1

ADDITIONAL INFORMATION:

- Default settings; 20W, 5000K.
- The color temperature and wattage may be adjusted by two slide switches integrated into the driver, selection should be made prior to installation.

