



Item **55753-8WEM**
LED 2X4 SPEC-SELECT™
BACK-LIT PANEL

2X4 LUMINARIES FOR AMBIENT LIGHTING OF INTERIOR COMMERCIAL SPACES

FEATURES

Spec-Select™ Backlit energy-efficient LED panels are like 9 fixtures in 1, and can provide the perfect balance of light in any application.

- Adjustable Wattage (3 settings)
- Adjustable Color (3 settings)
- Integrated Sensor option (ISO). Plug-in Motion + Daylight Sensor sold separately.
- 8W emergency battery pre-installed.

APPLICATION

Ideal for retrofitting inefficient fixtures in malls, hospitals, airports, offices, lobbies and other residential and commercial applications.

ELECTRICAL

Wattage	30W / 40W / 50W
Voltage	120-277V
Current	0.41-0.18A
Power Factor	0.9
Total Harmonic Distortion (THD)	10

LIGHTING PERFORMANCE

Lumens	3780 / 5040 / 6300
Lumens Per Watt (LPW)	126
Color Temperature (CCT)	3500K / 4100K / 5000K
Color Rendering (CRI)	83
R9 (Red Value)	8
Beam Angle	120°
Light Distribution	Type VS
BUG Rating (Backlight, Uplight, and Glare)	B2 - U2 - G1
Dimmable Lighting Control	From optional sensor, or customer 0-10V controls

ENVIRONMENT

Operating Temperature	-4° ~ 113°F
Suitable Location	DAMP
Ingress Protection Rating	IP40

LIFESPAN

Average Life (Hours)	50,000
Warranty (Years)	5

COMPONENTS

LED Light Source	Bridgelux 2835
Driver	SIF50-I1100-SS
Emergency Battery	55703
Sensor Socket	12VDC AUX.

CONSTRUCTION

Housing	Aluminum
Lens	Frosted
Base / Power Supply	Hard Wired
Finish	White

QUALIFICATIONS

Pending

Published lumens on LED products are approximate and may vary slightly. - Specifications are subject to change without notice.

Item#: **55753-8WEM**
LED 2X4 SPEC-SELECT™ BACK-LIT PANEL



ITEM INFORMATION

DIMENSIONS (Inches)

Length	47.6"
Width	23.8"
Height	1.6"
Weight (Lbs)	--

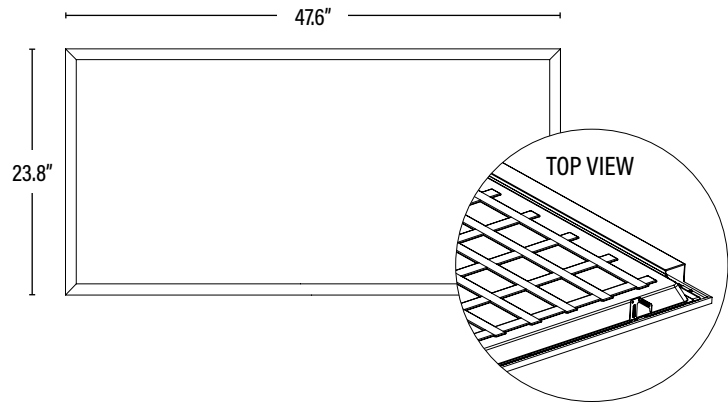

SUPPORTING DOCUMENTS (Grey = not available at this time.)

Product Sheet	VIEW
Install Instructions	VIEW
Emergency Battery	VIEW
IES Download from Web Item	VIEW
LM79	VIEW
LM80	VIEW

PACKAGING

		UPC	DIMENSIONS (LxWxH)	GROSS WEIGHT (Lbs)
Master Carton	2	10811768020875	49.3" x 3.8" x 25.6"	--
Individual Box	1	811768020878	N/A	--
Country of Origin	China			
HS Tariff	9405.11.6020			

ORDERING

ITEM#	DESCRIPTION	CASE
55753-8WEM	LED 2X4 SPEC-SELECT™ PANEL/BLP/30-40-50W/35-50K/DIMM/ISO/120-277V/8W EMB	2

ACCESSORIES

54880	BI-LEVEL AND DAYLIGHT PIR SENSOR FOR LED PANEL/UP TO 12FT HEIGHT • 12-24V DC	100
55129	2X4 FLANGE KIT FOR PANEL & TROFFER/WHT	1
55532	2X4 SURFACE MOUNTED KIT FOR LED BACK-LIT PANEL/WHT	1
55445	5FT SUSPENDED CABLE MOUNTING KIT FOR LED PANEL	100
55446	10FT SUSPENDED CABLE MOUNTING KIT FOR LED PANEL	100

REPLACEMENT PARTS

55703	EMERGENCY PACK FOR LED PANEL 8W/90 MIN	10
SIF50-11100-SS	REPLACEMENT LED DRIVER	1

ADDITIONAL INFORMATION:

- Default settings; 30W, 5000K.
- The color temperature and wattage may be adjusted by two slide switches integrated into the driver, selection should be made prior to installation.

