

Item#: **55754-B**
LED 1X4 SPEC-SELECT™
BACK-LIT PANEL

1X4 LUMINARIES FOR AMBIENT LIGHTING OF INTERIOR COMMERCIAL SPACES

FEATURES

Spec-Select™ Backlit energy-efficient LED panels are like 9 fixtures in 1, and can provide the perfect balance of light in any application.

- Adjustable Wattage (3 settings)
- Adjustable Color (3 settings)

APPLICATION

Ideal for retrofitting inefficient fixtures in malls, hospitals, airports, offices, lobbies and other residential and commercial applications.

ELECTRICAL

Wattage	25W / 30W / 40W
Voltage	120-277V
Current	0.33-0.14A
Power Factor	0.9
Total Harmonic Distortion (THD)	13.5

LIGHTING PERFORMANCE

Lumens	2750 / 3300 / 4400
Lumens Per Watt (LPW)	110
Color Temperature (CCT)	3500K / 4100K / 5000K
Color Rendering (CRI)	83
R9 (Red Value)	8
Beam Angle	120°
Light Distribution	Type VS
BUG Rating (Backlight, Uplight, and Glare)	B2 - U1 - G1
Dimmable Lighting Control	<i>Dimmable</i> 0-10V, Range 10% - 100%

ENVIRONMENT

Operating Temperature	-4° ~ 113°F
Suitable Location	DAMP
Ingress Protection Rating	IP40

LIFESPAN

Average Life (Hours)	50,000
Warranty (Years)	5

COMPONENTS

LED Light Source	Bridgelux 2835
Driver	SIF40-I1050

CONSTRUCTION

Housing	Aluminum
Lens	Frosted
Base / Power Supply	Hard Wired
Finish	Black Trim

QUALIFICATIONS

Model Number	55754
--------------	-------



Visit www.designlights.org/search to confirm qualification. • Published lumens on LED products are approximate and may vary slightly. • Specifications are subject to change without notice.

Item#: **55754-B**
LED 1X4 SPEC-SELECT™ BACK-LIT PANEL



ITEM INFORMATION

DIMENSIONS (Inches)

Length	47.6"
Width	11.9"
Height	1.6"
Weight (Lbs)	--

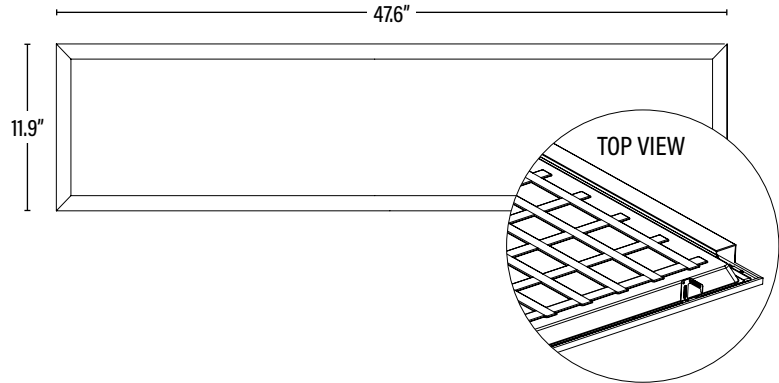

SUPPORTING DOCUMENTS (Grey = not available at this time.)

Product Sheet	VIEW
Install Instructions	VIEW
IES Download from Web Item	VIEW
LM79	VIEW
LM80	VIEW

PACKAGING

		UPC	DIMENSIONS (LxWxH)	GROSS WEIGHT (Lbs)
Master Carton	2	--	49.2" x 13.6" x 3.2"	--
Individual Box	1	--	N/A	--
Country of Origin	China			
HS Tariff	--			

ORDERING

ITEM#	DESCRIPTION	CASE
55754-B	LED 1X4 SPEC-SELECT™ PANEL/BLP/25-30-40W/35-50K/DIMM/120-277V/BLK TRIM - DLC®	2

ACCESSORIES

55445	5FT SUSPENDED CABLE MOUNTING KIT FOR LED PANEL	100
55446	10FT SUSPENDED CABLE MOUNTING KIT FOR LED PANEL	100

REPLACEMENT PARTS

SIF40-I1050	REPLACEMENT LED DRIVER	1
-------------	------------------------	---

ADDITIONAL INFORMATION:

- Default settings; 25W, 5000K.
- The color temperature and wattage may be adjusted by two slide switches integrated into the driver, selection should be made prior to installation.

