



Item#: **55755**

**LED 2X2 SPEC-SELECT™
BACK-LIT PANEL**

2X2 LUMINARIES FOR AMBIENT LIGHTING OF
INTERIOR COMMERCIAL SPACES

FEATURES

Spec-Select™ Backlit energy-efficient LED panels are like 9 fixtures in 1, and can provide the perfect balance of light in any application.

- Adjustable Wattage (3 settings)
- Adjustable Color (3 settings)

APPLICATION

Ideal for retrofitting inefficient fixtures in malls, hospitals, airports, offices, lobbies and other residential and commercial applications.

ELECTRICAL

Wattage	25W / 30W / 40W
Voltage	120-277V
Current	0.33-0.14A
Power Factor	0.9
Total Harmonic Distortion (THD)	10.9

LIGHTING PERFORMANCE

Lumens	2750 / 3300 / 4440
Lumens Per Watt (LPW)	110
Color Temperature (CCT)	3500K / 4100K / 5000K
Color Rendering (CRI)	82
R9 (Red Value)	7
Beam Angle	120°
Light Distribution	Type VS
BUG Rating (Backlight, Uplight, and Glare)	B2 - U1 - G1
Dimmable Lighting Control	<i>Dimmable</i> 0-10V, Range 10% - 100%

ENVIRONMENT

Operating Temperature	-4° ~ 113°F
Suitable Location	DAMP
Ingress Protection Rating	IP40

LIFESPAN

Average Life (Hours)	50,000
Warranty (Years)	5

COMPONENTS

LED Light Source	Bridgelux 2835
Driver	SIF40-I1050

CONSTRUCTION

Housing	Aluminum
Lens	Frosted
Base / Power Supply	Hard Wired
Finish	White

QUALIFICATIONS



Visit www.designlights.org/search to confirm qualification. - Published lumens on LED products are approximate and may vary slightly. - Specifications are subject to change without notice.

Item#: **55755**
LED 2X2 SPEC-SELECT™ BACK-LIT PANEL



ITEM INFORMATION

DIMENSIONS (Inches)

Length	23.8"
Width	23.8"
Height	1.6"
Weight (Lbs)	--

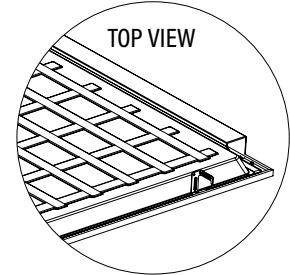
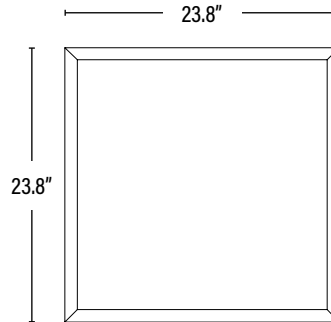

SUPPORTING DOCUMENTS (Grey = not available at this time.)

Product Sheet	VIEW
Install Instructions	VIEW
IES Download from Web Item	VIEW
LM79	VIEW
LM80	VIEW

PACKAGING

		UPC	DIMENSIONS (LxWxH)	GROSS WEIGHT (Lbs)
Master Carton	2	10811768029243	25.2" x 25.6" x 3.2"	17
Individual Item	1	811768029246	N/A	8.5
Country of Origin	China			
HS Tariff	9405.11.6020			

ORDERING

ITEM#	DESCRIPTION	CASE
55755	LED 2X2 SPEC-SELECT™ PANEL/BLP/25-30-40W/35-50K/DIMM/120-277V - DLC®	2

ACCESSORIES

55128	2X2 FLANGE KIT FOR PANEL & TROFFER/WHT	1
55531	2X2 SURFACE MOUNTED KIT FOR LED BACK-LIT PANEL/WHT	1
55445	5FT SUSPENDED CABLE MOUNTING KIT FOR LED PANEL	100
55446	10FT SUSPENDED CABLE MOUNTING KIT FOR LED PANEL	100
55706	EMERGENCY PACK FOR LED BLP PANEL 8W/90 MIN	10
55393	MOUNTING BRACKET AND WIRE BOXES FOR EMERGENCY PACK FOR LED 2X2 OR 2X4 PANEL	20
55697	DUAL COLOR TAPE TEST BUTTON AND ADAPTOR FOR EMERGENCY BATTERY TROFFER OR PANEL	400

REPLACEMENT PARTS

SIF40-11050	REPLACEMENT LED DRIVER	1
-------------	------------------------	---

ADDITIONAL INFORMATION:

- Default settings; 25W, 5000K.
- The color temperature and wattage may be adjusted by two slide switches integrated into the driver, selection should be made prior to installation.

