



Item#: **55756**

**LED 2X4 SPEC-SELECT™
BACK-LIT PANEL**

2X4 LUMINARIES FOR AMBIENT LIGHTING OF
INTERIOR COMMERCIAL SPACES

FEATURES

Spec-Select™ Backlit energy-efficient LED panels are like 9 fixtures in 1, and can provide the perfect balance of light in any application.

- Adjustable Wattage (3 settings)
- Adjustable Color (3 settings)

APPLICATION

Ideal for retrofitting inefficient fixtures in malls, hospitals, airports, offices, lobbies and other residential and commercial applications.

ELECTRICAL

Wattage	30W / 40W / 50W
Voltage	120-277V
Current	0.42-0.18A
Power Factor	0.9
Total Harmonic Distortion (THD)	10.3

LIGHTING PERFORMANCE

Lumens	3330 / 4440 / 5550
Lumens Per Watt (LPW)	111
Color Temperature (CCT)	3500K / 4100K / 5000K
Color Rendering (CRI)	82
R9 (Red Value)	5
Beam Angle	120°
Light Distribution	Type VS
BUG Rating (Backlight, Uplight, and Glare)	B2 - U1 - G1
Dimmable Lighting Control	<i>Dimmable</i> 0-10V, Range 10% - 100%

ENVIRONMENT

Operating Temperature	-4° ~ 113°F
Suitable Location	DAMP
Ingress Protection Rating	IP40

LIFESPAN

Average Life (Hours)	50,000
Warranty (Years)	5

COMPONENTS

LED Light Source	Bridgelux 2835
Driver	SIF50-I1250

CONSTRUCTION

Housing	Aluminum
Lens	Frosted
Base / Power Supply	Hard Wired
Finish	White

QUALIFICATIONS



Visit www.designlights.org/search to confirm qualification. • Published lumens on LED products are approximate and may vary slightly. • Specifications are subject to change without notice.

Item#: **55756**
LED 2X4 SPEC-SELECT™ BACK-LIT PANEL



ITEM INFORMATION

DIMENSIONS (Inches)

Length	47.6"
Width	23.8"
Height	1.6"
Weight (Lbs)	--

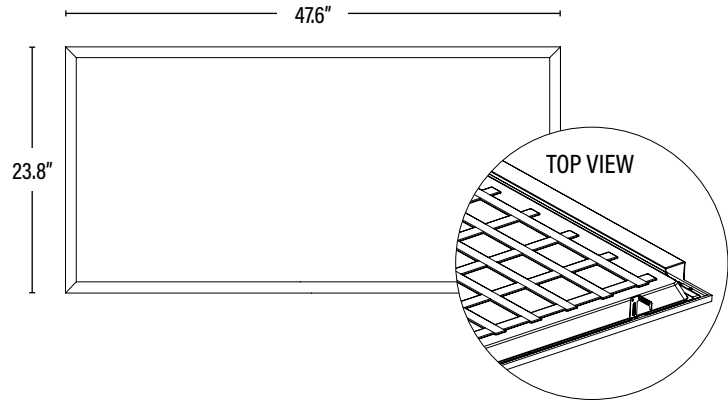

SUPPORTING DOCUMENTS (Grey = not available at this time.)

Product Sheet	VIEW
Install Instructions	VIEW
IES Download from Web Item	VIEW
LM79	VIEW
LM80	VIEW

PACKAGING

		UPC	DIMENSIONS (LxWxH)	GROSS WEIGHT (Lbs)
Master Carton	2	10811768024262	49.2" x 25.6" x 3.2"	32.9
Individual Box	1	811768024265	N/A	16.4
Country of Origin	China			
HS Tariff	9405.11.6020			

ORDERING

ITEM#	DESCRIPTION	CASE
55756	LED 2X4 SPEC-SELECT™ PANEL/BLP/30-40-50W/35-50K/DIMM/120-277V - DLC®	2

ACCESSORIES

55129	2X4 FLANGE KIT FOR PANEL & TROFFER/WHT	1
55532	2X4 SURFACE MOUNTED KIT FOR LED BACK-LIT PANEL/WHT	1
55445	5FT SUSPENDED CABLE MOUNTING KIT FOR LED PANEL	100
55446	10FT SUSPENDED CABLE MOUNTING KIT FOR LED PANEL	100
55706	EMERGENCY PACK FOR LED BLP PANEL 8W/90 MIN	10
55393	MOUNTING BRACKET AND WIRE BOXES FOR EMERGENCY PACK FOR LED 2X2 OR 2X4 PANEL	20
55697	DUAL COLOR TAPE TEST BUTTON AND ADAPTOR FOR EMERGENCY BATTERY TROFFER OR PANEL	400

REPLACEMENT PARTS

SIF50-11250	REPLACEMENT LED DRIVER	1
-------------	------------------------	---

ADDITIONAL INFORMATION:

- Default settings; 30W, 5000K.
- The color temperature and wattage may be adjusted by two slide switches integrated into the driver, selection should be made prior to installation.

