

Item#: **55759**
LED 4' SPEC-SELECT™
ARCHITECTURAL DESIGNER STRIP
DIRECT LINEAR AMBIENT LUMINARIES

FEATURES

Spec-Select™ Architectural Designer Strips are like 9 fixtures in 1, featuring adjustable wattage and color temperature for the perfect balance of light in any application.

- Adjustable Wattage (3 settings)
- Adjustable Color (3 settings)
- Integrated Sensor Option (ISO). Sensor and elbow sold separately.
- Easy installation.

APPLICATION

Ideal for larger warehouses, retail applications, commercial buildings and work areas.

ELECTRICAL

Wattage	34W / 38W / 45W
Voltage	120-277V
Current	45W @ 120V = 0.375A
Power Factor	0.9
Total Harmonic Distortion (THD)	8.6

LIGHTING PERFORMANCE

Lumens	4420 / 4940 / 5850
Lumens Per Watt (LPW)	130
Color Temperature (CCT)	3500K / 4100K / 5000K
Color Rendering (CRI)	81
R9 (Red Value)	4
Beam Angle	130°
Light Distribution	Type II, Very Short
BUG Rating (Backlight, Uplight, and Glare)	B2 - U3 - G2
Dimmable Lighting Control	From optional 12VDC sensor, or customer 0-10V controls.

ENVIRONMENT

Operating Temperature	-4 ~ 122°F
Suitable Location	DAMP
Ingress Protection Rating	IP40

LIFESPAN

Average Life (Hours)	50,000
Warranty (Years)	5

COMPONENTS

LED Light Source	Bridgelux
Driver	SIF40-I1000-SS
Sensor Socket	12VDC AUX.

CONSTRUCTION

Housing	Aluminum
Lens	Frosted
Base / Power Supply	Hard Wired
Finish	White

QUALIFICATIONS



Visit www.designlights.org/search to confirm qualification. • Published lumens on LED products are approximate and may vary slightly. • Specifications are subject to change without notice.

Item#: **55759**
LED 4' SPEC-SELECT™ ARCHITECTURAL DESIGNER STRIP



ITEM INFORMATION

DIMENSIONS (Inches)

Length	47.3"
Width	1.9"
Height	2.5"
Net Weight (Lbs)	--

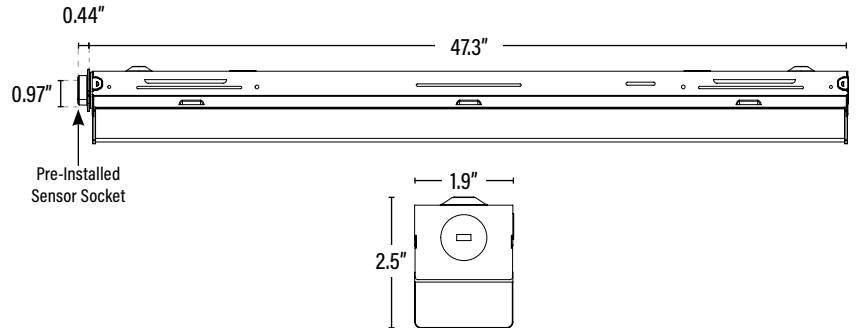

SUPPORTING DOCUMENTS (Grey = not available at this time.)

Product Sheet	VIEW
Install Instructions	VIEW
IES Download from Web Item	VIEW
LM79	VIEW
LM80	VIEW

PACKAGING

		UPC	DIMENSIONS (LxWxH)	GROSS WEIGHT (Lbs)
Master Carton	6	10811768022909	49.3" x 7.2" x 8.7"	--
Individual Box	1	811768022902	48.6" x 2.2" x 2.7"	--
Country of Origin	China			
HS Tariff	9405.11.6020			

ORDERING

ITEM#	DESCRIPTION	CASE
55759	LED 4FT SPEC-SELECT™ ARCHITECTURAL DESIGNER STRIP/34-38-45W/35-50K/DIMM/ISO/120-277V - DLC®	6

ACCESSORIES

54871	BI-LEVEL PIR MOTION & DAYLIGHT SCREW-IN SENSOR FOR ISO STRIPS & VAPOR TIGHTS/40FT (REQUIRES 12-24VDC AUX & ELBOW #54876)	100
54872	BI-LEVEL MICROWAVE MOTION & DAYLIGHT SCREW-IN SENSOR FOR ISO STRIPS & VAPOR TIGHTS/40FT (REQUIRES 12-24VDC AUX & ELBOW #54876)	100
54876	EXTERNAL SWIVEL QUICK CONNECT ADJUSTABLE ELBOW FOR 54871/54872 (For best sensor performance.)	100
55703	EMERGENCY PACK FOR SLIM LED STRIP/VAPOR TIGHT 8W/90 MIN	10
55454	ROW ALIGNER FOR DESIGNER STRIP	100
45001	V HOOK FOR HANGING DESIGNER STRIP FIXTURE (2 PER SET)	100

REPLACEMENT PARTS

557598	REPLACEMENT LENS ONLY	1
54875	REPLACEMENT QUICK CONNECT SOCKET BASE FOR ISO	1
OBC-DS	OUTLET BOX COVER FOR DESIGNER STRIP	1
SIF40-11000-SS	REPLACEMENT DRIVER	1

ADDITIONAL INFORMATION:

- Default settings; 34W, 5000K.
- The color temperature and wattage may be adjusted by two slide switches integrated into the driver. For additional information refer to the install instructions.

