



Item#: **55761**  
**LED 2' SPEC-SELECT™**  
**DESIGNER STRIP**

**DIRECT LINEAR AMBIENT LUMINARIES**

**FEATURES**

Spec-Select™ Designer Strips are like 9 fixtures in 1, featuring adjustable wattage and color temperature for the perfect balance of light in any application.

- Adjustable Wattage (3 settings)
- Adjustable Color (3 settings)
- Integrated Sensor Option (ISO). Sensor and elbow sold separately.
- Easy installation.

**APPLICATION**

Ideal for larger warehouses, retail applications, commercial buildings and work areas.

**ELECTRICAL**

Wattage	15W / 20W / 25W
Voltage	120-277V
Current	25W @ 120V = 0.20A
Power Factor	0.9
Total Harmonic Distortion (THD)	14.1

**LIGHTING PERFORMANCE**

Lumens	1980 / 2640 / 3300
Lumens Per Watt (LPW)	132
Color Temperature (CCT)	3500K / 4100K / 5000K
Color Rendering (CRI)	83
R9 (Red Value)	6
Beam Angle	130°
Light Distribution	Type II, Very Short
BUG Rating (Backlight, Uplight, and Glare)	B1 - U3 - G1
Dimmable Lighting Control	From optional 12VDC sensor, or customer 0-10V controls.

**ENVIRONMENT**

Operating Temperature	-4 ~ 122°F
Suitable Location	<b>DAMP</b>
Ingress Protection Rating	IP40

**LIFESPAN**

Average Life (Hours)	50,000
Warranty (Years)	<b>5</b>

**COMPONENTS**

LED Light Source	Bridgelux
Driver	SIF30-I0550-SS
Sensor Socket	12VDC AUX.

**CONSTRUCTION**

Housing	Aluminum
Lens	Frosted
Base / Power Supply	Hard Wired
Finish	White

**QUALIFICATIONS**



Visit [www.designlights.org/search](http://www.designlights.org/search) to confirm qualification. • Published lumens on LED products are approximate and may vary slightly. • Specifications are subject to change without notice.

Item#: **55761**  
**LED 2' SPEC-SELECT™ DESIGNER STRIP**



ITEM INFORMATION

**DIMENSIONS** (Inches)

Length	22.2"
Width	1.9"
Height	2.5"
Net Weight (Lbs)	--

**SUPPORTING DOCUMENTS** (Grey = not available at this time.)

Product Sheet	VIEW
Install Instructions	VIEW
IES Download from Web Item	VIEW
LM79	VIEW
LM80	VIEW

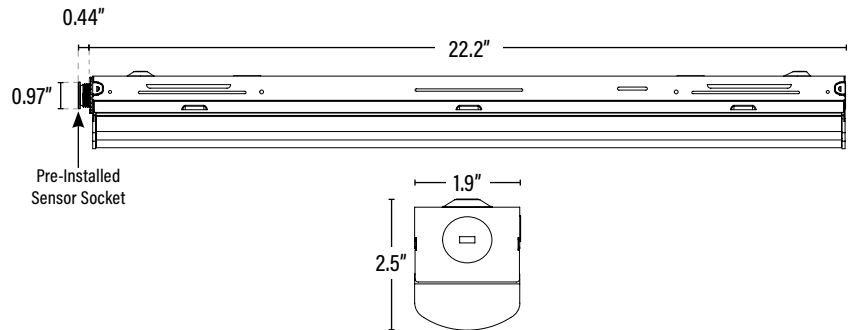

**PACKAGING**

		UPC	DIMENSIONS (LxWxH)	GROSS WEIGHT (Lbs)
Master Carton	6	10811768026396	23.2" x 6.8" x 8.4"	--
Individual Box	1	811768026399	22.7" x 2.2" x 2.7"	--
Country of Origin	China			
HS Tariff	--			

**ORDERING**

ITEM#	DESCRIPTION	CASE
55761	LED 2FT SPEC-SELECT™ DESIGNER STRIP/15-20-25W/35-50K/DIMM/ISO/120-277V - DLC®	6

**ACCESSORIES**

54871	BI-LEVEL PIR MOTION & DAYLIGHT SCREW-IN SENSOR FOR ISO STRIPS & VAPOR TIGHTS/40FT (REQUIRES 12-24VDC AUX & ELBOW #54876)	100
54872	BI-LEVEL MICROWAVE MOTION & DAYLIGHT SCREW-IN SENSOR FOR ISO STRIPS & VAPOR TIGHTS/40FT (REQUIRES 12-24VDC AUX & ELBOW #54876)	100
54876	EXTERNAL SWIVEL QUICK CONNECT ADJUSTABLE ELBOW FOR 54871/54872 (For best sensor performance.)	100
55454	ROW ALIGNER FOR DESIGNER STRIP	100
45001	V HOOK FOR HANGING DESIGNER STRIP FIXTURE (2 PER SET)	100

**REPLACEMENT PARTS**

54875	REPLACEMENT QUICK CONNECT SOCKET BASE FOR ISO	1
OBC-DS	OUTLET BOX COVER FOR DESIGNER STRIP	1
SIF30-I0550-SS	REPLACEMENT DRIVER	1

**ADDITIONAL INFORMATION:**

- Default settings; 15W, 5000K.
- The color temperature and wattage may be adjusted by two slide switches integrated into the driver. For additional information refer to the install instructions.

