

LED EMERGENCY LIGHT - #82360

INSTALL INSTRUCTIONS

PLEASE FIND A QUALIFIED ELECTRICIAN FOR INSTALLATION. Please read the instructions before you install and use the emergency light.

GENERAL: ALL ELECTRICAL CONNECTIONS MUST BE IN ACCORDANCE WITH LOCAL AND NATIONAL ELECTRICAL CODE (N.E.C.) STANDARDS. IF YOU ARE UNFAMILIAR WITH PROPER ELECTRICAL WIRING CONNECTIONS OBTAIN THE SERVICES OF A QUALIFIED ELECTRICIAN.

WARNINGS, CAUTIONS AND OPERATING INSTRUCTIONS

When using electrical equipment, basic safety precautions should always be followed, including:

- Make all electrical connections in accordance with local codes, ordinances, and the National Electric Code.
- This product is for indoor use only.
- Do not mount this product near a gas or electric heater.
- Use caution when servicing batteries. Battery acid can cause burns to skin and eyes. If acid is spilled on skin or eyes, flush acid with fresh water and contact a physician immediately.
- This product should be mounted in a location and at a height where it will not be readily subjected to tampering by unauthorized personnel.
- The use of accessories is not recommended by the manufacturer, and may cause unsafe conditions.
- Do not use this product for anything other than its intended use.
- Changes or modifications to this unit not expressly approved by the party responsible for compliance could void the user's authority to operate the equipment.
- This device complies with part 15 of the FCC rules. Operation is subject to the following two conditions: (1) This device may not cause harmful interference, and (2) this device must accept any interference received, including interference that may cause undesired operation.
- All service shall be performed by qualified service personnel. This product must be installed and maintained in accordance with the applicable installation codes by a person familiar with the construction operation of the product and the hazards involved.
- Suitable for damp locations.
- Suitable for use in 32°F to 104°F (0°C to 40°C) ambient temperature.
- **MAX. MOUNTING HEIGHT: 8FT 8IN**

! WARNING DISCONNECT POWER BEFORE INSTALLING OR SERVICING.

IMPORTANT: When constructing or remodeling and prior to installing, be sure to check with the local fire marshal or code enforcement office to ensure the correct guidelines for your municipality are being followed.

TOOLS REQUIRED:



Safety Glasses

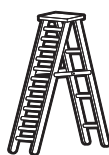

Ladder

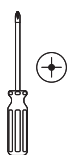

Philips Screwdriver

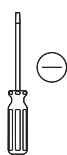

Flat Screwdriver

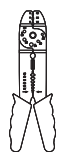

Wire Strippers



Wire Cutters

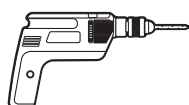

Drill



3/16" Drill Bit

HARDWARE INCLUDED:

PART	DESCRIPTION	QUANTITY
	Mounting Screw	2
	Wall Anchor	2
	Wire Nut	3

Before beginning assembly, installation, or operation of the product, make sure all parts are present. Compare parts with the package contents list. If any part is missing or damaged, do not attempt to assemble, install, or operate the product. Contact customer service.

SAVE THESE INSTRUCTIONS

LED EMERGENCY LIGHT - #82360

INSTALL INSTRUCTIONS

PQL
PREMIUM QUALITY LIGHTING®

! WARNING DISCONNECT POWER BEFORE INSTALLING OR SERVICING.

STEP 1 - PREP THE FIXTURE

1. Insert a small flat screwdriver into the top of the locking tabs (D) and carefully pry the locking tabs (D) away from the housing (A) until they release from the housing (A).
2. Gently pull the backplate away from the housing (A).

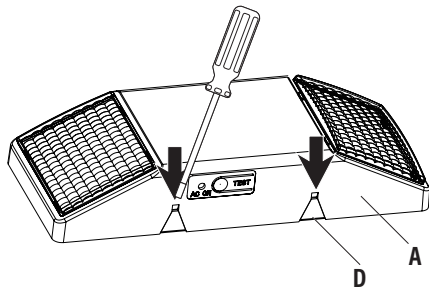

FIXTURE DIAGRAM

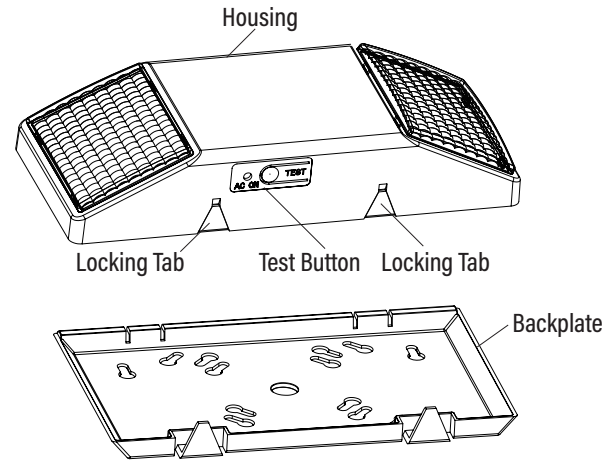

STEP 2 - INSTALLATION

JBOX INSTALLATION & MOUNTING (FIG. 1 & 2)

1. Feed the fixture wires through the backplate (B) and connect them to the power supply using the wire nuts (BB).
2. For 120V or 277V applications, use the red and white wires. Connect the red supply HOT wire to the black fixture wire. Connect the NEUTRAL supply wire to the white fixture wire.
3. Cap the unused wire using provided wire nut (BB).
4. Attach the backplate (B) to the junction box using the junction box screws (not included).

FIG. 1

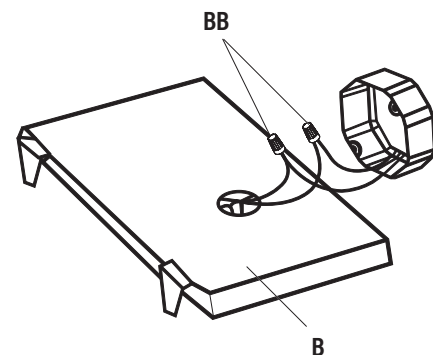
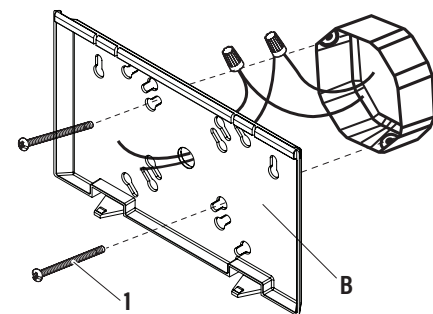

FIG. 2



LED EMERGENCY LIGHT - #82360

INSTALL INSTRUCTIONS

! WARNING DISCONNECT POWER BEFORE INSTALLING OR SERVICING.

CONDUIT INSTALLATION & MOUNTING (FIG. 3)

WARNING: USE FLEXIBLE CONDUIT ONLY

This product must be installed in accordance with the applicable building codes, electric codes, and ordinances. Be sure to comply with your local and state regulations. It is recommended that this product be installed by a licensed electrician or by qualified service personnel.

1. Route the wires through the hole in the conduit flange (1a) or through the rear of the backplate (B) (1b) and make the conduit connection in accordance with code requirements.
2. For 120V or 277V applications, use the red and white wires. Connect the red supply HOT wire to the black fixture wire. Connect the NEUTRAL supply wire to the white fixture wire.
3. Using the backplate (B) as a template, mark and drill two installation holes on the wall at the desired installation location.
4. Insert wall anchors (CC) into the holes.
5. Attach the backplate (B) to the wall by inserting screws (AA) through the backplate (B) and into the wall anchors (CC).

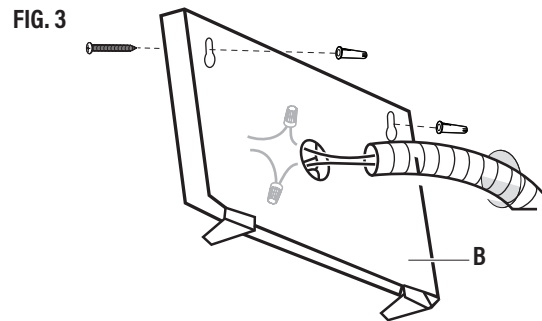

STEP 3 - CONNECT BACK-UP BATTERY (FIG. 4)

1. Connect the PCB board connector to the battery connector.
2. Allow 24 hours to fully charge the back-up battery before testing.

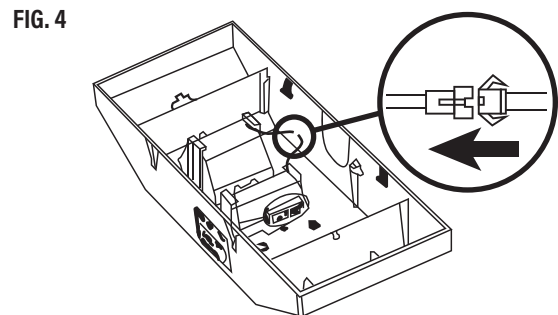

STEP 4 - COMPLETE INSTALLATION (FIG. 5)

1. Align the locking tabs and push the housing (A) directly onto the backplate (B).
2. Restore power to the fixture. The Test switch (C) should illuminate.

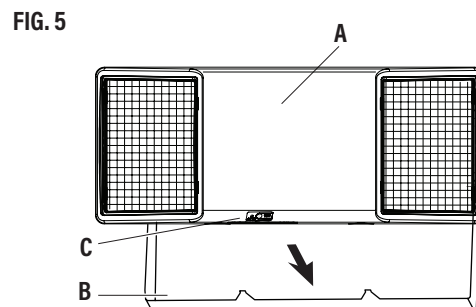

LED EMERGENCY LIGHT - #82360

INSTALL INSTRUCTIONS

! WARNING DISCONNECT POWER BEFORE INSTALLING OR SERVICING.

MAINTENANCE (FIG. 7)

NOTE: National Electric Code (NEC) and NFPA life safety code regulations require that routine tests need to be performed.

- Allow the battery to charge at least 24 hours before testing.
- To test the fixture, press the TEST button on the bottom of the fixture. The LED lamps should turn on.
- Test the fixture regularly.

TEST THE BATTERY

Test the unit's battery once per month. Additionally, every 12 months, a full 90-minute test should be performed. While disconnected from the main power supply, the unit should illuminate for a minimum of 90 minutes on battery back up power.

BATTERY REPLACEMENT (FIG. 8)

This fixture uses a Ni-Cd Rechargeable AA700 mAh 3.6V battery.

To remove the battery:

1. Bend the battery catches away from the battery and remove the battery from the housing.
2. Disconnect the battery leads from the board terminal leads.
3. Connect the new battery to the board terminal leads.
4. Place the new battery in the battery location and ensure it is seated behind the battery catches (1).

FIG. 7

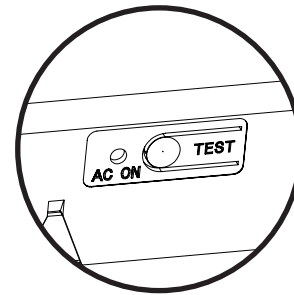
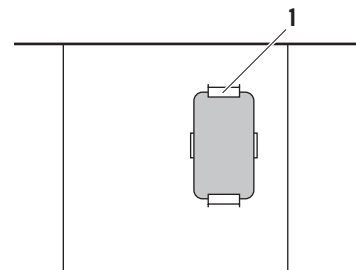

FIG. 8



TROUBLESHOOTING

Problem	Possible Cause	Solution
The LED charge indicator does not illuminate.	AC power supply is off.	Ensure the unit has AC power supply. Restore the power at the breaker/fuse box.
	The unit is incorrectly wired.	Ensure the unit is wired correctly.
	The battery isn't connected.	Ensure the battery is connected.
The LED emergency heads do not illuminate.	The battery is discharged.	Verify the unit is properly wired and connected to an AC power source. Allow the unit to charge for 24 hours and then re-test.
	The battery isn't connected.	Ensure the battery is connected.

If the above troubleshooting does not resolve the issue, contact a qualified electrician, or call customer service at 1-800-323-8107.

SAVE THESE INSTRUCTIONS