



Item#: **83088-W**
LED CANOPY
PARKING GARAGE LUMINAIRES

FEATURES

- Ultra-thin design.
- Replaces 100-175W MH.

HOUSING

- One piece sealed die cast housing.
- UV stabilized polycarbonate optical lens.

MOUNTING

- Surface Mount with J-Box.
- Pendant with 3/4" conduit.

APPLICATION

Parking structures and storage areas.

ELECTRICAL

Wattage	40W
Voltage	120-277V
Power Factor	0.9
Total Harmonic Distortion (THD)	20

LIGHTING PERFORMANCE

Lumens	4800
Lumens Per Watt (Lm/W)	120
Color Temperature (CCT)	5000K
Color Rendering (CRI)	80
R9 (Red Value)	27
R13 (Skin Tones)	84
Beam Angle	100° x 60°
Light Distribution	Type VS
BUG Rating (Backlight, Uplight, and Glare)	B2 - U2 - G1
Dimmable Lighting Control	<i>Dimmable</i> 0-10V, Range 10% - 100%

ENVIRONMENT

Operating Temperature	-40° ~ 104°F
Suitable Location	WET
Ingress Protection Rating	IP65

LIFESPAN

Average Life (Hours)	50,000
Warranty (Years)	5

COMPONENTS

LED Light Source	Seoul 3528
Driver	WP-HHA-040U042

CONSTRUCTION

Housing	Aluminum
Lens	PC / Frosted
Base / Power Supply	Hard Wired
Finish	White

QUALIFICATIONS



Visit www.designlights.org/search to confirm qualification. - Published lumens on LED products are approximate and may vary slightly. - Specifications are subject to change without notice.

Item#: **83088-W**
LED CANOPY



ITEM INFORMATION

DIMENSIONS (Inches)

Length	10.4"
Width/Diameter	10.4"
Height	3.5"
Net Weight (Lbs)	--

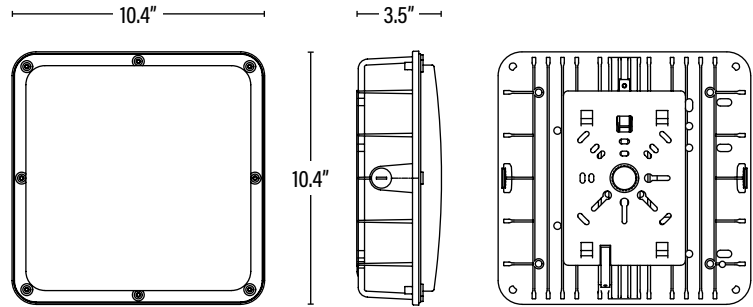

SUPPORTING DOCUMENTS (Grey = not available at this time.)

Product Sheet	VIEW
Install Instructions	VIEW
IES Download from Web Item	VIEW
LM79	VIEW
LM80	VIEW

PACKAGING

		UPC	DIMENSIONS (LxWxH)	GROSS WEIGHT (Lbs)
Master Carton	4	10811768023494	19.3" x 19.3" x 12.2"	7.3
Individual Box	1	811768023497	--	1.8
Country of Origin	China			
HS Tariff	9405.10.6020			

ORDERING

ITEM#	DESCRIPTION	CASE
83088-W	LED CANOPY/40W/50K/DIMM/120-277V/WHT - DLC®	4

ACCESSORIES

54888	360° BI-LEVEL AND DAYLIGHT HARVESTING MICROWAVE SENSOR 26' DIA, 8-40' HEIGHT 800W/1200W - 120/277V	100
-------	--	-----

REPLACEMENT PARTS

WP-HHA-040U042	REPLACEMENT 40W DIMMABLE LED DRIVER	1
----------------	-------------------------------------	---

ADDITIONAL INFORMATION:

Note: To prevent water damage which may shorten the life of an exterior mounted fixture; the fixture should be properly weather sealed according to the installation instructions or between the fixture base and mounting surface. Damage due to improper installation may void the warranty.