

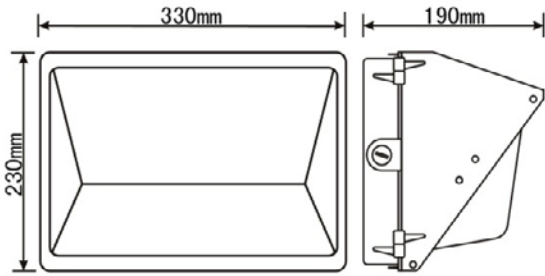

PREMIUM QUALITY LIGHTING

83122/83120

LED MEDIUM WALL PACK/90-277V
INSTALL INSTRUCTIONS



PLEASE FIND A QUALIFIED ELECTRICIAN FOR INSTALLATION.
Please read the instruction before you install and use the luminaire.

83122 LED MEDIUM WALL PACK 40W 100-240/277V 50/60HZ AC
83120 LED MEDIUM WALL PACK 60W 100-240/277V 50/60HZ AC

Suitable for indoor and outdoor, moisture proof and dust proof.

IMPORTANT: To weather-proof your outdoor installation, be sure to seal all mounting bracket with silicone sealant.



LISTED
E363076

USAGE

1. Please check the box to see if there is damage or not before opening the box. Please check the attached technical documents such as brochures, factory certificate and check to see if there is damage of lamps.
2. The lamp will be directly fixed on the mounting surface as shown below with the mounting hardware during installation.

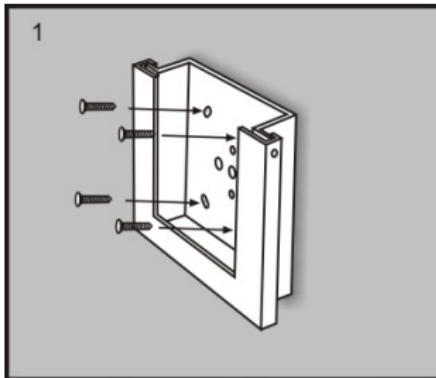
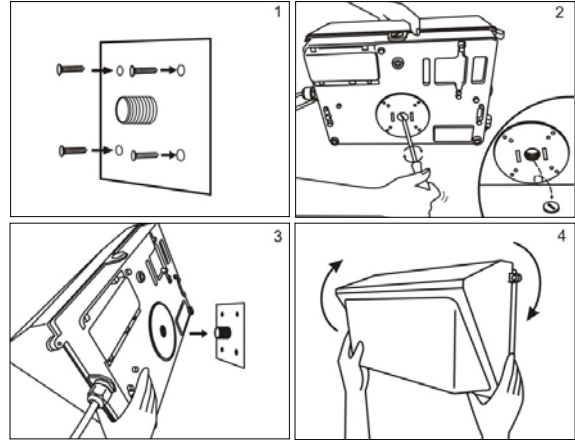

1. Mount the big bracket to wall in place with the supplied screws. Please make sure the bracket slot upward and ensure it's horizontal.

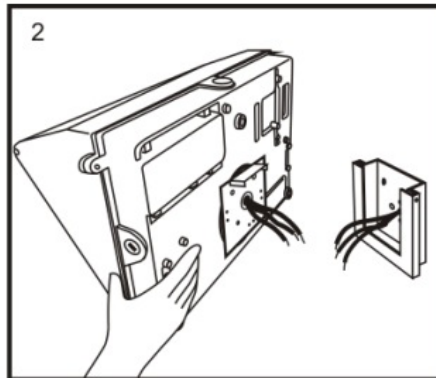

2. Leave the wires for both sides and prepare wiring.

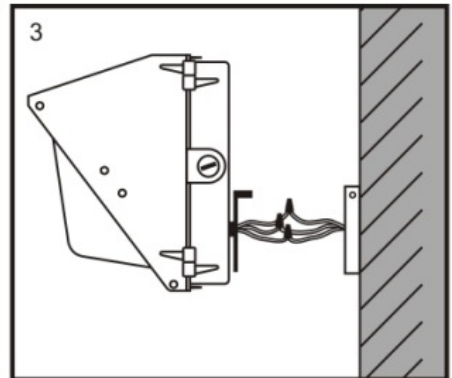

3. Take the fixture and connect the wires to the corresponding same color of wires (white, black, green) from the lamp and the wall. Please ensure all wires are correctly connected.

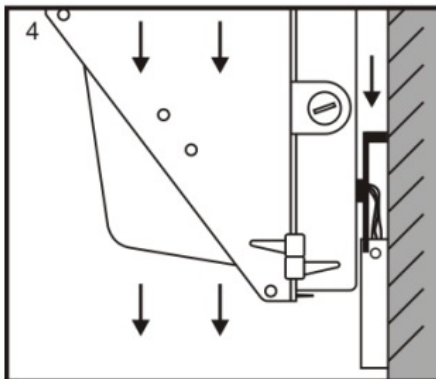

4. Align the fixture with the bracket on wall and slide it down into the slot.

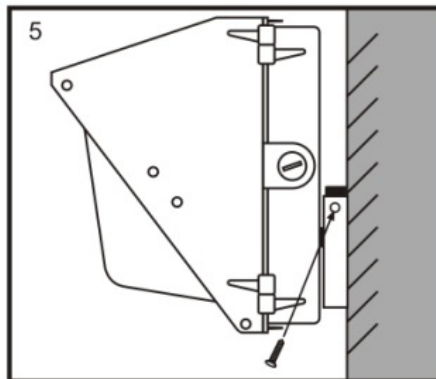

5. Screw from the two sides of the bracket to strengthen the bracket to make sure the fixture won't fall down.

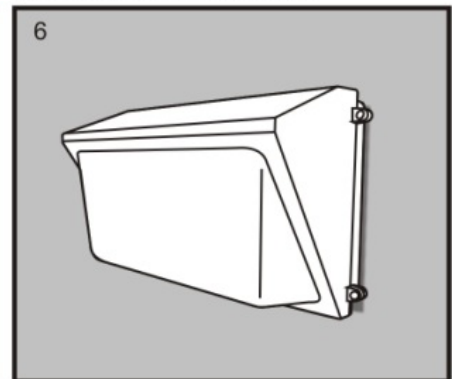

6. Effect image
Please note the small bracket on fixture and the other one on wall must be horizontal so the whole fixture won't be declining after being mounted.

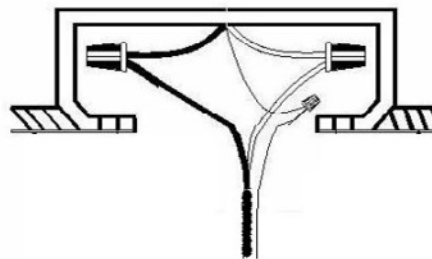
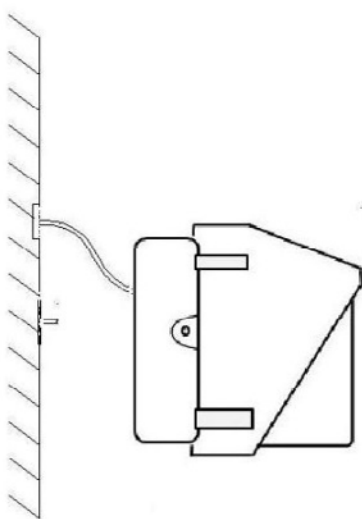

3. Wiring construction.

Wiring method: Wire the black line to the cable L (live wire), and white one to line N (null line), yellow-green one to G (ground) inside outlet box (figure above). After all the installation is finished and fine, power on the lamp and it will works.



WARNINGS



Disconnect power to sensor by turning OFF circuit breaker or removing the fuse for the circuit before installing, replacing lamps or doing any electrical work.

- The socket must be containing ground lead.
- Please confirm the power source is in compliance with the rating of the luminaire and make sure the luminaire had been mounting correctly.
- Make sure the luminaire had been mounting correctly before connect to the power source.
- If the luminaire can not work normally please turn to a professional maintenance worker to repair the fixture, do not open the luminaire arbitrarily.