



SELV IP65



(for 48V,54V only)



(except for 48V,54V)



■ Features :

- Universal AC input / Full range (up to 305VAC)
- Built-in active PFC function
- Protections: Short circuit / Over current / Over voltage / Over temperature
- Cooling by free air convection
- OCP point adjustable through output cable or internal potentiometer
- IP67 / IP65 design for indoor or outdoor installations
- Class 2 power unit
- Three in one dimming function (1~10Vdc or PWM signal or resistance)
- Suitable for LED lighting and moving sign applications
- Compliance to worldwide safety regulations for lighting
- Suitable for dry / damp / wet location
- 5 years warranty (Note.10)

A : IP65 rated. Output voltage and constant current level can be adjusted through internal potentiometer.

SPECIFICATION

MODEL		HLG-60H-15A
OUTPUT	DC VOLTAGE	15V
	CONSTANT CURRENT REGION Note.4	9 ~ 15V
	RATED CURRENT	4A
	RATED POWER	60W
	RIPPLE & NOISE (max.) Note.2	150mVp-p
	VOLTAGE ADJ. RANGE Note.6	13.5 ~ 17V
	CURRENT ADJ. RANGE	Can be adjusted by internal potentiometer A type only 2.4 ~ 4A
	VOLTAGE TOLERANCE Note.3	±2.0%
	LINE REGULATION	±0.5%
	LOAD REGULATION	±1.5%
INPUT	SETUP, RISE TIME Note.8	500ms, 80ms at full load 230VAC / 115VAC
	HOLD UP TIME (Typ.)	16ms/230VAC 16ms/115VAC at full load
	VOLTAGE RANGE Note.5	90 ~ 305VAC 127 ~ 431VDC
	FREQUENCY RANGE	47 ~ 63Hz
	POWER FACTOR (Typ.)	PF>0.98/115VAC, PF>0.95/230VAC, PF>0.92/277VAC at full load (Please refer to "Power Factor Characteristic" curve)
	TOTAL HARMONIC DISTORTION	THD< 20% when output loading≥60% at 115VAC/230VAC input and output loading≥75% at 277VAC input
	EFFICIENCY (Typ.)	87.5%
	AC CURRENT (Typ.)	0.64A / 115VAC 0.32A / 230VAC 0.3A / 277VAC
PROTECTION	INRUSH CURRENT(Typ.)	COLD START 55A(twidth=265µs measured at 50% Ipeak) at 230VAC
	LEAKAGE CURRENT	<0.75mA / 277VAC
	OVER CURRENT Note.4	95 ~ 108% Protection type : Constant current limiting, recovers automatically after fault condition is removed
	SHORT CIRCUIT	Hiccup mode, recovers automatically after fault condition is removed
ENVIRONMENT	OVER VOLTAGE	18 ~ 24V Protection type : Shut down o/p voltage, re-power on to recover
	OVER TEMPERATURE	Shut down o/p voltage, re-power on to recover
	WORKING TEMP.	-40 ~ +70°C (Refer to "Derating Curve")
	WORKING HUMIDITY	20 ~ 95% RH non-condensing
SAFETY & EMC	STORAGE TEMP., HUMIDITY	-40 ~ +80°C, 10 ~ 95% RH
	TEMP. COEFFICIENT	±0.03%/°C (0 ~ 60°C)
	VIBRATION	10 ~ 500Hz, 5G 12min./1cycle, period for 72min. each along X, Y, Z axes
	SAFETY STANDARDS Note.7	UL8750, CSA C22.2 No. 250.0-08 (except for 48V, 54V), EN61347-1, EN61347-2-13 independent, IP65 or IP67, J61347-1, J61347-2-13 approved ; design refer to UL60950-1, TUV EN60950-1, EN60335-1
	WITHSTAND VOLTAGE	I/P-O/P:3.75KVAC I/P-FG:2KVAC O/P-FG:1.5KVAC
OTHERS	ISOLATION RESISTANCE	I/P-O/P, I/P-FG, O/P-FG:100M Ohms / 500VDC / 25°C/ 70% RH
	EMC EMISSION	Compliance to EN55015, EN61000-3-2 Class C (≥60% load) ; EN61000-3-3
	EMC IMMUNITY	Compliance to EN61000-4-2,3,4,5,6,8,11; EN61547, EN55024, light industry level (surge 4KV), criteria A
NOTE	MTBF	338Khrs min. MIL-HDBK-217F (25°C)
	DIMENSION	171*61.5*36.8mm (L*W*H)
	PACKING	0.73Kg; 20pcs/15.6Kg/0.8CUFT

1. All parameters NOT specially mentioned are measured at 230VAC input, rated load and 25°C of ambient temperature.
2. Ripple & noise are measured at 20MHz of bandwidth by using a 12" twisted pair-wire terminated with a 0.1uf & 47uf parallel capacitor.
3. Tolerance : includes set up tolerance, line regulation and load regulation.
4. Please refer to "DRIVING METHODS OF LED MODULE".
5. Derating may be needed under low input voltages. Please check the static characteristics for more details.
6. A type only.
7. Safety and EMC design refer to EN60598-1, CNS15233, GB7000.1, FCC part18.
8. Length of set up time is measured at cold first start. Turning ON/OFF the power supply may lead to increase of the set up time.
9. The power supply is considered as a component that will be operated in combination with final equipment. Since EMC performance will be affected by the complete installation, the final equipment manufacturers must re-qualify EMC Directive on the complete installation again.
10. Refer to warranty statement.
11. To fulfill requirements of the latest ErP regulation for lighting fixtures, this LED power supply can only be used behind a switch without permanently connected to the mains.

Mechanical Specification

Case No.957B Unit:mm

A Type:(HLG-60H-_A)

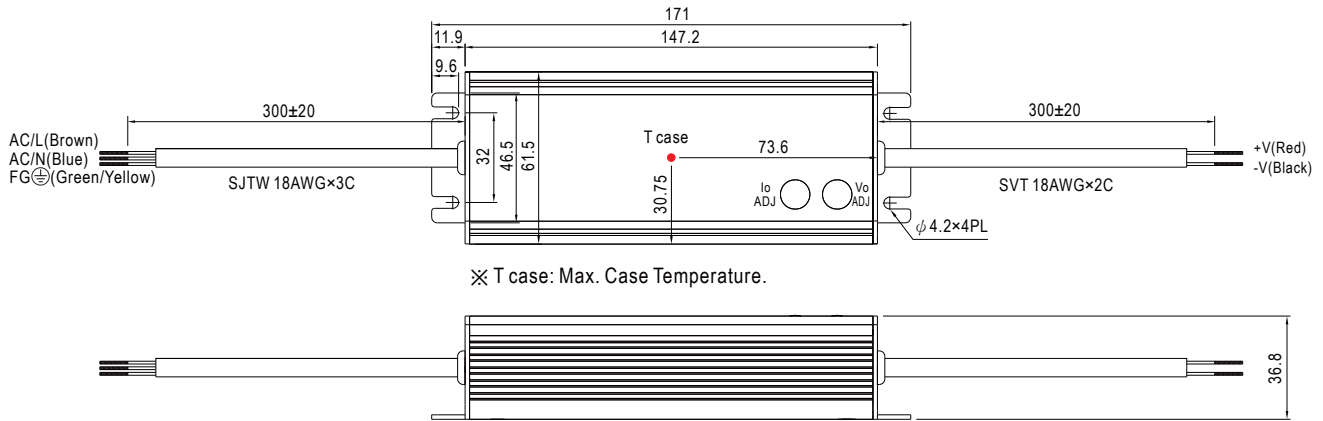

※ T case: Max. Case Temperature.

※ IP65 rated. Output voltage and constant current level can be adjusted through internal potentiometer. (Can access by removing the rubber stopper on the case.)

Block Diagram

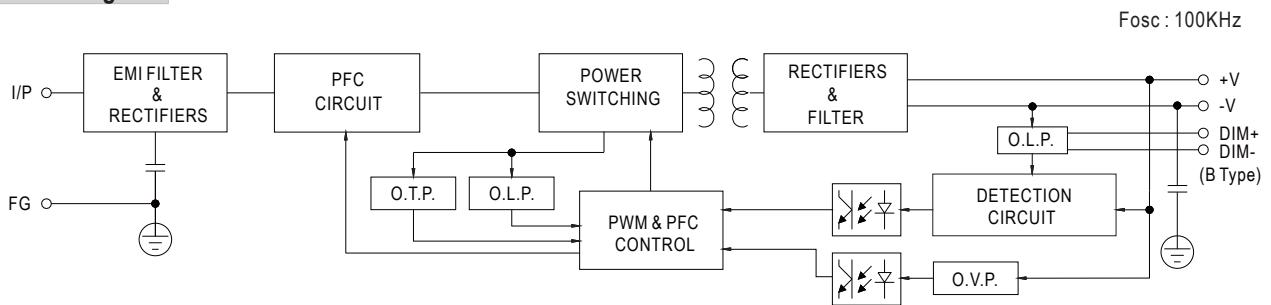

Derating Curve

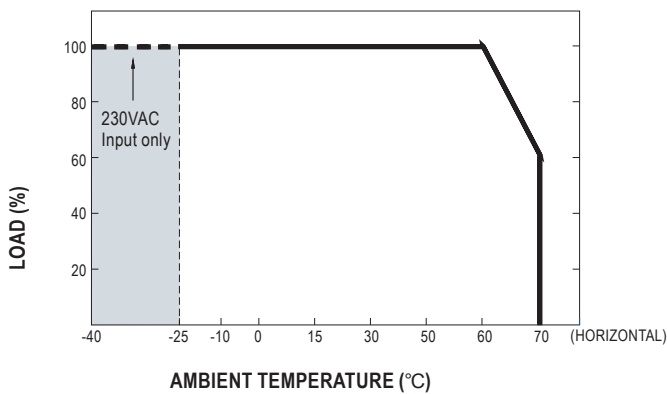

Static Characteristics

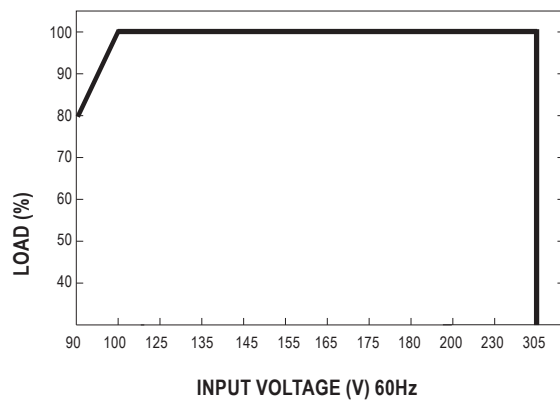

Power Factor Characteristic

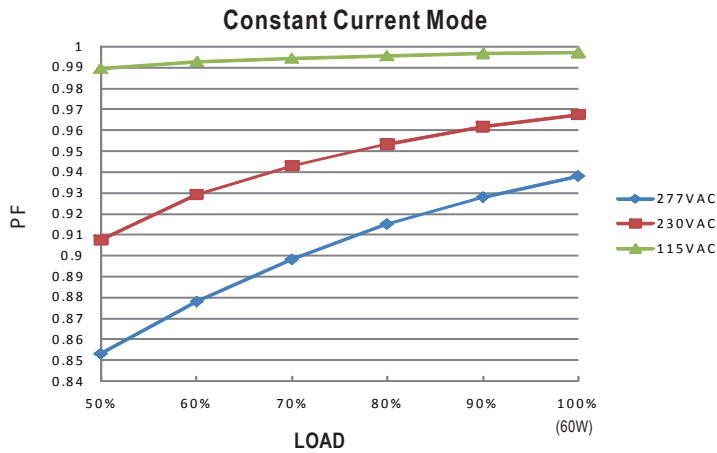

EFFICIENCY vs LOAD (48V Model)

HLG-60H series possess superior working efficiency that up to 90.5% can be reached in field applications.

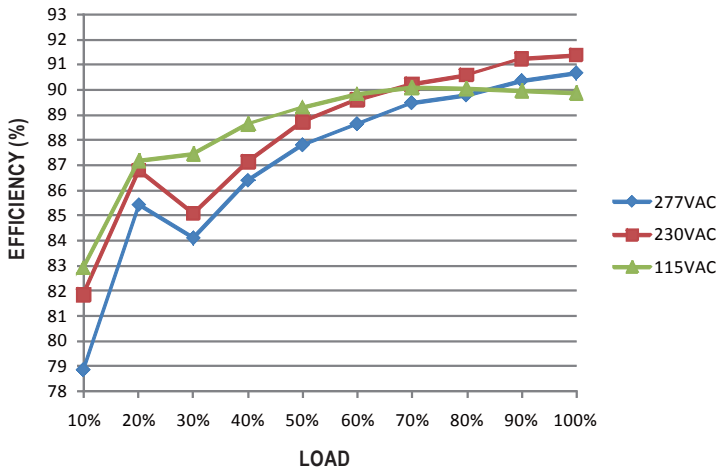

DRIVING METHODS OF LED MODULE

There are two major kinds of LED drive method "direct drive" and "with LED driver".

A typical LED power supply may either work in "constant voltage mode (CV) or constant current mode (CC)" to drive the LEDs.

Mean Well's LED power supply with CV+ CC characteristic can be operated at both CV mode (with LED driver, at area (A) and CC mode (direct drive, at area (B)).

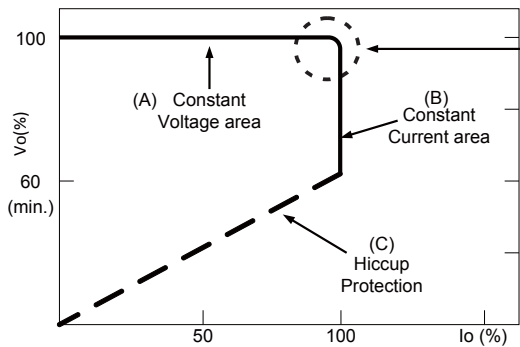

In the constant current region, the highest voltage at the output of the driver depends on the configuration of the end systems.

Should there be any compatibility issues, please contact MEAN WELL.

■ WATERPROOF CONNECTION

◎ Waterproof connector

Waterproof connector can be assembled on the output cable of HLG-60H to operate in dry/wet/damp or outdoor environment.

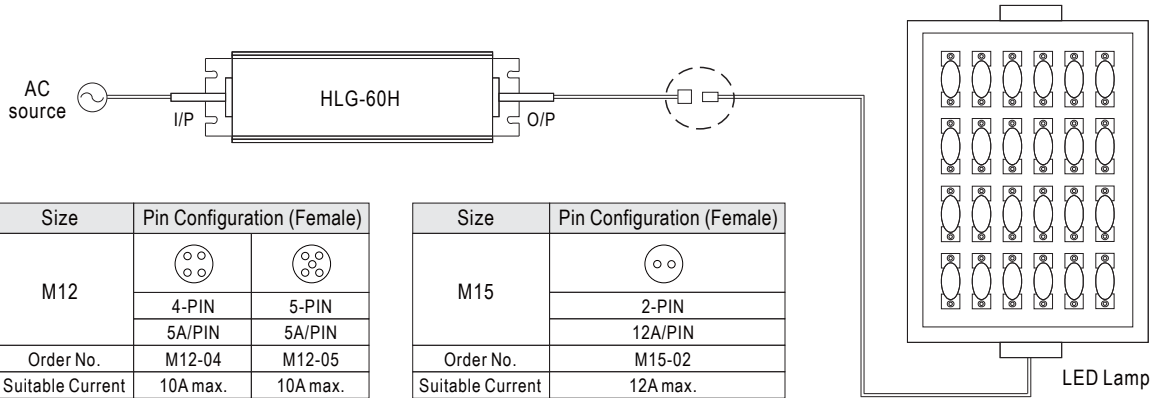

◎ Cable Joiner

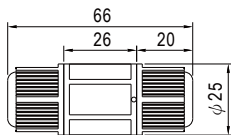

CJ04-1 suitable for 14AWG~16AWG
CJ04-2 suitable for 18AWG~22AWG



Up to four wires can be connected through this cable joiner by soldering or clamping by tools.

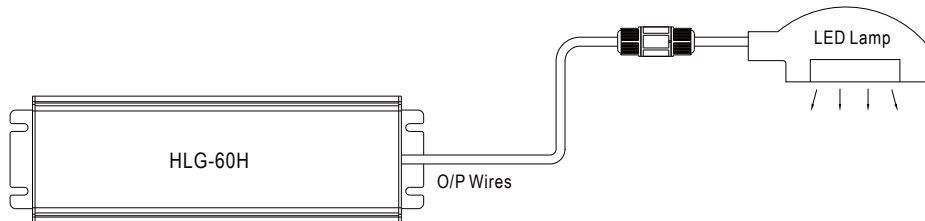
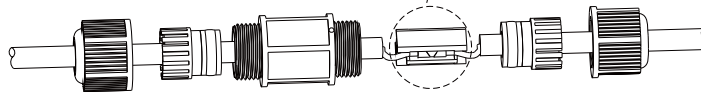

※CJ04 cable joiner can be purchased independently for user's own assembly.
MEAN WELL order No. : CJ04-1, CJ04-2.