



Item#: **84089**

LED STADIUM LIGHT

OUTDOOR POLE/ARM-MOUNTED AREA AND ROADWAY LUMINAIRES - ARCHITECTURAL FLOOD AND SPOT LUMINAIRES

FEATURES

- Elegant and modern appearance.
- Numerous vents to improve heat management.
- Instant-On, No Flickering or Humming.
- Solid state design.
- Multi-faceted optic design to distribute light evenly and reduce glare.
- Advanced technology, no electrical interference.
- 240° adjustable angle.
- Surge protection device provides single phase protection.

APPLICATION

Arenas, gymnasiums, plazas, airports, courtyards and public areas.

LIGHT DISTRIBUTION CURVE

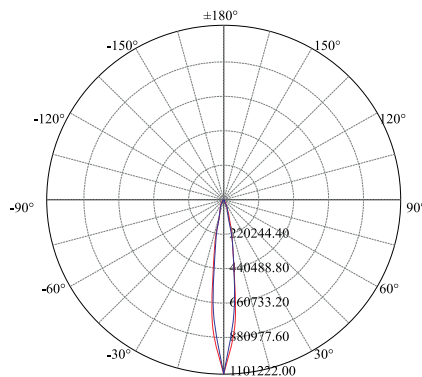

ELECTRICAL

Wattage	607W
Voltage	240-480V
Power Factor	0.9
Total Harmonic Distortion (THD)	14.6

LIGHTING PERFORMANCE

Lumens	72039
Lumens Per Watt (Lm/W)	119
Color Temperature (CCT)	3000K
Color Rendering (CRI)	70
R9 (Red Value)	--
R13 (Skin Tones)	--
Beam Angle	40°
Light Distribution	Type I, Very Short
Dimmable Lighting Control	<i>Dimmable</i>

ENVIRONMENT

Operating Temperature	-30°C ~ 50°C
Suitable Location	WET
Ingress Protection Rating	IP66

LIFESPAN

Average Life (Hours)	50,000
Warranty (Years)	5

COMPONENTS

LED Light Source	Osram Duris® P8
Driver	HVG-150-48B (4 ea.)

CONSTRUCTIONS

Housing	Aluminum
Lens	PC
Base / Power Supply	Hard Wired
Finish	Black
Effective Projected Area (EPA)	2.29 ft²

CERTIFICATIONS



Published lumens on LED products are approximate and may vary slightly.

PERFORMANCE DATA

PACKAGING

Item#: **84089**
LED STADIUM LIGHT



DIMENSIONS (Inches)

Length	22.9"
Width/Diameter	18.6"
Height	--
Weight (Lbs)	61.3

Line drawings may not be to scale and are for general reference only.

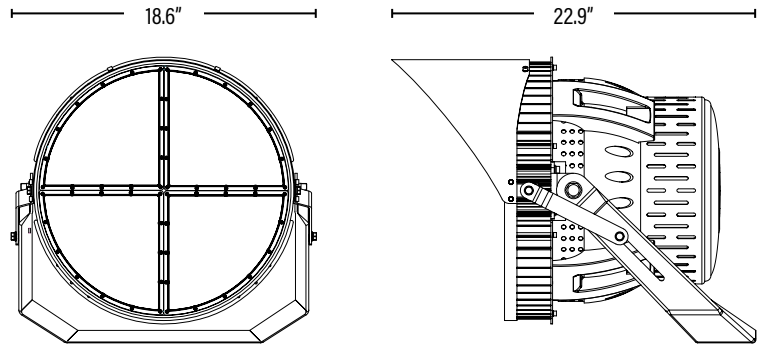

SUPPORTING DOCUMENTS (Grey = not available at this time.)

Product Sheet	VIEW
Install Instructions	VIEW
IES Download from Web Item	VIEW
LM79	VIEW
LM80	VIEW

PACKAGING

Master Carton	1pc
Country of Origin	China
HS Tariff	9405.40.8200

UPC

--

DIMENSIONS (LxWxH)

24.8" x 24.4" x 24.4"

GROSS WEIGHT (Lbs)

69.9

ORDERING

ITEM#	DESCRIPTION	CASE
84089	LED 600W STADIUM/30K/40°/240-480V - SUPERIOR LIFE®	1

ADDITIONAL INFORMATION:

These are only offered as SPECIAL ORDER (not stocked) and a minimum order quantity will apply. The lead-time is approximately 60 to 75 days.

PERFORMANCE DATA

PACKAGING