

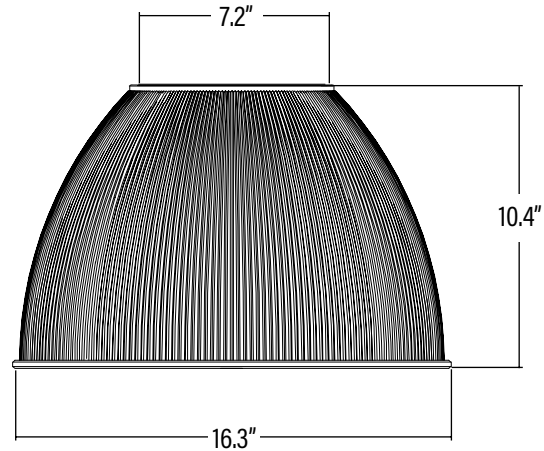

Item#: **90400**
16" ACRYLIC REFLECTOR
ACCESSORY



APPLICATION

Acrylic reflector for use with High Bay Fixtures.

DIMENSIONS (Inches)

Length (MOL)	10.4"
Width/Diameter (MOD)	16.3"
Net Weight (Lbs)	3.6

PACKAGING

		UPC	DIMENSIONS (LxWxH)	GROSS WEIGHT (Lbs)
Master Carton	10	10811768025351	18.5" x 24" x 18.5"	36.4
Individual Item	1	811768025354	See Dimensions Above	
Country of Origin	China			
HS Tariff	9405.99.4090			

ORDERING

ITEM#	DESCRIPTION	CASE
90400	16" ACRYLIC REFLECTOR FOR LED HIGH BAY HOUSING - SUPERIOR LIFE®	10

ACCESSORIES

90363	16" ACRYLIC BOTTOM LENS FOR ACRYLIC REFLECTOR FOR COMPASS HIGH BAY - SUPERIOR LIFE®	1
-------	---	---