



PREMIUM QUALITY LIGHTING

90414

LED 100W HIGH BAY WITH ACRYLIC REFLECTOR

TECHNICAL DATA SHEET



FEATURES



HIGH-BAY LUMINAIRES FOR COMMERCIAL AND INDUSTRIAL BUILDINGS

- Housing: High-purity aluminum heat sink
- Pressure tight optic cover
- 3-D Heat dissipation
- Nichia 3030 LED chips
- Meanwell Driver
- Dimming: 0-10V

APPLICATION

Replaces existing metal halide and HPS fixtures.



Dimmable
LED

SPECIFICATIONS

Power Consumption	100W
Input Voltage	100-277V
Lumens	11689
Luminous Efficiency	123 Lm/W
Color Temperature	4000K
CRI	75
Beam Angle	110°
Finish	Silver
Dimensions (Inches)	22"(L) x 16.3"(DIA)

LIFESPAN & ENVIRONMENT

Average Life	50,000
Operating Temperature	-30°C ~ 50°C

DIMENSIONS

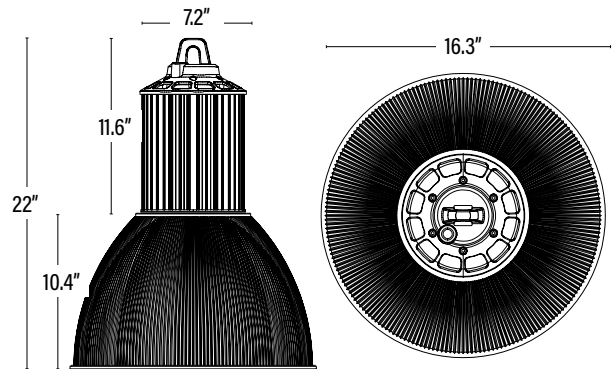

ORDERING

ITEM#	DESCRIPTION	WATTS	COLOR	LUMENS	CRI	VOLT	HOUSING	HOURS	CASE
90414	LED 100W HIGH BAY/4000K/100-277V/DIMMABLE - SL® (DLC w/90400)	100	4000K	11689	75	100-277V	SILVER	50,000	1

Please check DLC website for the most current list of approved items - www.designlights.org
Published lumens on LED products are approximate and may vary slightly.

P.Q.L., INC. • 2285 WARD AVENUE • SIMI VALLEY, CA 93065 • 800.323.8107 • FAX: 877.619.7053
www.PQLighting.com