



ENERGY STAR® Luminaire Test Report

ENERGY STAR® Program Requirements Product Specification for Luminaires - Version 2.2 August 15, 2019

Prepared For

P.Q.L., Inc.

2285 Ward Avenue / Simi Valley, CA 93065

Test Laboratory: UL-CCIC Company Limited

Test Laboratory Address: 2, Chengwan Road, Suzhou Industrial Park, Suzhou 21522 China

Catalog Number

92150, TSRC-4-JBX

Project Number

4789880982.63.1-2

Report Number

4789880982.63.1-2

Test Date

2/18/2022 -3/19/2022

Issue Date

4/1/2022

Revision Date

N/A

Prepared By

Zoe Guo

Handler signature

Approved By

Duff Yang

Reviewer signature

This report contains data that are not covered by the NVLAP accreditation.

The results contained in this report pertain only to the tested sample. This report shall not be reproduced, except in full, without written approval of Underwriters Laboratories. This report must not be used by the client to claim product certification, approval, or endorsement by NVLAP, NIST, or any agency of the U.S. Government. The laboratory is not responsible for the information which provided by customer, its authenticity can affect the validity of the result in the test report.



ENERGY STAR® Program Requirements Product Specification for Luminaires - Version 2.2 - Issued 2019-08-15

LED Recessed Downlight/SSL Downlight retrofits			
Requirement Category	Test Method	Requirement	Test Value
Efficacy (lm/W)	IES LM-79-08	Downlights: • Recessed • Surface • Pendant: 55 lm/W, Downlights retrofits: 60lm/w	87.2
Light Output (lm)	IES LM-79-08	≤ 4.5" aperture: 345 lumens > 4.5" aperture: 575 lumens	790.4
Zonal Lumen Density	IES LM-79-08	For directional luminaires only.	86.2%
CCT (K)	ANSI C78.377-2015 or C78.377-2017	fall within the corresponding 7-step chromaticity quadrangles	2693
CRI	IES LM-79-08, CIE 13.3-1995	Ra ≥ 80	92
R9	IES LM-79-08, CIE 13.3-1996	R9 > 0	50
Color Angular Uniformity	IES LM-79-08, CIE 15: 2004	≤ 0.006 on the CIE 1976 (u',v') diagram	0.001
Lumen Maintenance & Light Source Life (hours)	N/A	L70 ≥ 25,000 hours for indoor; L70 ≥ 35,000 hours for outdoor; L70 ≥ 50,000 h for inseparable luminaires	50000
Color Maintenance	IES LM-84-14	≤ 0.007 on the CIE 1976 (u',v') diagram	0.001
Source Start Time (ms)	ENERGY STAR Start Time Test Method	1 s for connected luminaires; 750 ms for other luminaires.	78.35
Source Run-Up Time (s)	ENERGY STAR Run Up Time Test Method	≤ 45 seconds	N/A
Power Factor	C82.77-10:2014	power ≤ 5 watts: PF ≥ 0.5; power ≥ 5 watts: PF ≥ 0.7	0.8186
Transient Protection	IEEE C62.41.2-2002	Survival	Survival
Standby Power Consumption (W)	IEC 62301 ED.2.0 B	Shall not draw power in the off state.	N/A
Operating Frequency (Hz)*	N/A	Frequency ≥ 120 Hz	120.2

* The data are not covered by the NVLAP accreditation.



Test Summary (Cont'd)

Requirement Category	Test Method	Requirement	Test Value
Flicker: Short Term Flicker Indicator (Pst)*	NEMA 77-2017	Optional: meet NEMA 77-2017 for temporal light modulation limits.	8.178
Flicker: Stroboscopic Visibility Measure (SVM)*	NEMA 77-2017	Optional: meet NEMA 77-2017 for temporal light modulation limits.	1.564
Light Source Replaceability	N/A	Fluorescent & Directional LED luminaire	N/A
LED Tc Temperature (°C)	ANSI/UL 1598:2008 ANSI/UL 153-2002	Within the highest test temperature in LM-80 report	94.1
Driver Case Temperature (°C)	ANSI/UL 1598:2008 ANSI/UL 153-2002	≤ TMPC marked on the the driver	91.4
Recessed Downlight Thermal Performance	N/A	Insulation contact & Airtight construction	Type IC
SAFETY REQUIREMENTS for luminaire and driver	UL Safety standards	Safety documentation	Vatidated
Dimming: Range (Minimum)	N/A	≤20%	1.14%
Dimming: Noise*	N/A	24dBA at 1 meter	18.1
Labeling & Packaging	N/A	Relevant document	N/A
WARRANTY REQUIREMENTS	N/A	no less than 3 years	5
Lighting Toxics Reduction Requirements	N/A	Relevant Documentations	N/A

* The data are not covered by the NVLAP accreditation.



Test List

Sample Receive Date: 2022/2/15

Test Item	Test	Test Date	Test Model	Equipment ID.	Tests Conducted By
1	Integrating Sphere Test	2/21/2022	TSRC-4-JBX	N/A	Zoe Guo
3	Goniophotometer Test	2/18/2022	TSRC-4-JBX	N/A	Zoe Guo
5	Color Angular Uniformity	2/18/2022	TSRC-4-JBX	N/A	Zoe Guo
6	Source Start Time & Run-Up time	2/24/2022	TSRC-4-JBX	N/A	Zoe Guo
7	Operating Frequency Test	2/24/2022	TSRC-4-JBX	N/A	Zoe Guo
8	Transient Protection Test	2/25/2022	TSRC-4-JBX	N/A	Zoe Guo
9	Standby Power Consumption	N/A	N/A	N/A	N/A
10	Flicker Test	2/24/2022	TSRC-4-JBX	N/A	Zoe Guo
11	Dimming Test	2/24/2022	TSRC-4-JBX	N/A	Zoe Guo
12	In-Situ Temperature Measurement Test	2/28/2022	TSRC-4-JBX	N/A	Zoe Guo
13	In-Situ Temperature Measurement Test	3/19/2022	92150	N/A	Zoe Guo

Remark (if any)

- 1. UL test equipment information is recorded on Meter Use in UL's Aurora database.
- 2. The accuracy method decision rule is applied when the compliance or verdict is made to the results of this report.



Production Description

Luminaire Description: LED Recessed Downlight/SSL Downlight retrofits

Lighting Source and Manufacturer: SL-ID2835FTA-31KAG, Shenzhen Smalite Semiconductor Co.,Ltd

LED Driver: TSRC4-10W-D

Electrical Parameter: 120VAC, 50/60Hz

Family model: 92150, TSRC-4-JBX

** means product color, and it can be WH, BZ, BK, NK. WH=White, BZ= Bronze, BK=Black, NK=Nickel.

* means product appearance, and it can be S, B. S=smooth, B=baffle

The Product is color tunable and dimmable. The CCT can be 2700k, 3000K, 3500K, 4000K, 5000K;

Least Efficient white light setting, Default setting and Most Consumptive white light setting are all 2700K.

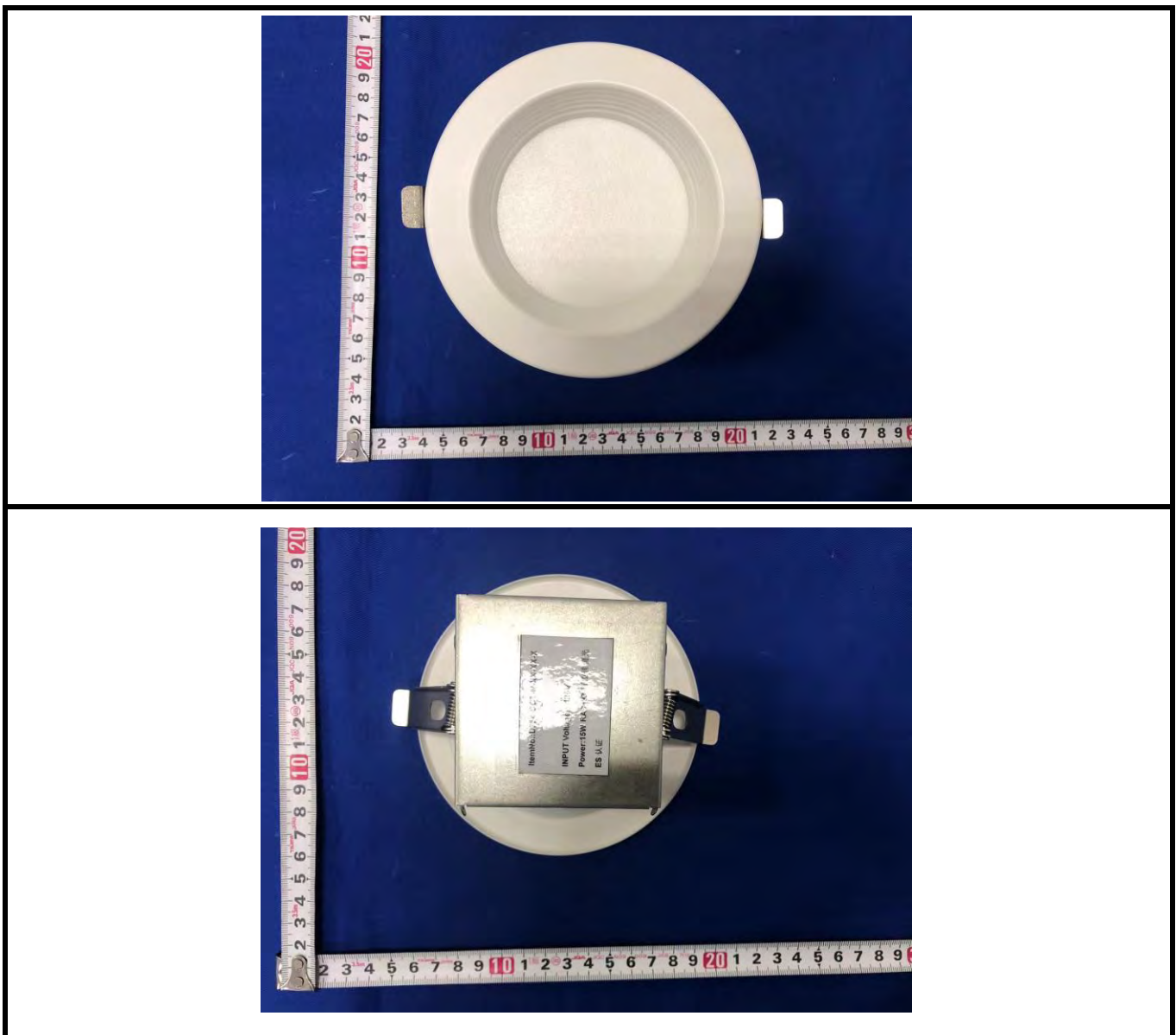



Integrating Sphere Test

Model No.	TSRC-4-JBX	Sample ID.	4651933	Temperature (°C)	25.4
Operate time (Min.)	90	Stabilization time (Min.)	45		

Test Method

1.The sample was tested according to the IES LM-79-2008, and the product is assume to be brand new without seasoning.

2.Photometric parameters were measured using an integrating sphere, a spectroradiometer and software. The ambient temperature condition inside the sphere was maintained at 25 °C ± 1 °C. The reference standard lamp is rated current 2.679A omni-directional Incandescent lamp and was calibrated by National Institute of Metrology P.R.China.

3.The sample measurements were made using a spectroradiometer connected by a fiber optic cable and detector through the detector port of the integrating sphere. Coating reflectance of the integrating sphere was 90% to 98%. Photometric measurement conditions was using 4π geometry. The self-absorption factor is applied in the final test result. The sample was operated at rated voltage and was stabilized before measurement. Chromaticity coordinates, correlated color temperature and color rendering index were calculated from the spectral radiant flux measurements taken at 1 nm intervals over the range of 380 to 780 nm.

Integrating Sphere Conditions and Results

Model Number	Orientation	Voltage (Vac)	Frequency (Hz)	Current (A)	Power (W)	Power Factor	CCT (K)	CRI (Ra)	R9	Luminous Flux (lm)	Luminous Efficacy (lm/W)
TSRC-4-JBX (2700K)	Horizontal	119.93	59.96	0.0933	9.13	0.8186	2693	92	50	798.5	87.42
TSRC-4-JBX (5000K)	Horizontal	119.94	59.96	0.0932	9.11	0.8153	5168	92	59	908.1	99.71



Goniophotometer Test

Model No.	TSRC-4-JBX	Sample ID.	4651933
Opreate time (Min.)	90	Stabilization time (Min.)	45

Test Method

1. The sample was tested according to the IES LM-79-2008.
 2. Photometric paramters were measured using a type C goniophotometer and software.
 3. The ambient temperature shall be maintained at 25° C ± 1° C, measured at a point not more than 1 m from the sample and at the same height as the sample.
 4. The samples were operated at rated voltage and was stabilized before measurement. Luminous flux, luminaire efficacy, zonal lumen were calculated from the software taken at 1° vertical intervals and 22.5° horizontal intervals.

Goniophotometer Test Conditions

Temperature (°C)	Voltage (Vac)	Frequency (Hz)	Current (A)	Power (W)	Power Factor	Orientation
24.6	120.04	60.00	0.0920	9.06	0.8213	Horizontal

Test Results

Flux (lm)	Zonal Lumen Requirement (0-60°)	Field Angle (10%)		Beam Angle (50%)		Luminous Efficacy (lm/W)
		Horizontal Spread	Vertical Spread	Horizontal Spread	Vertical Spread	
790.4	86.2%	144.6	144.5	106.7	106.9	87.2
Zonal Lumen Requirement 2						
N/A						



Goniophotometer Test (Cont'd)

Light Distribution Curve

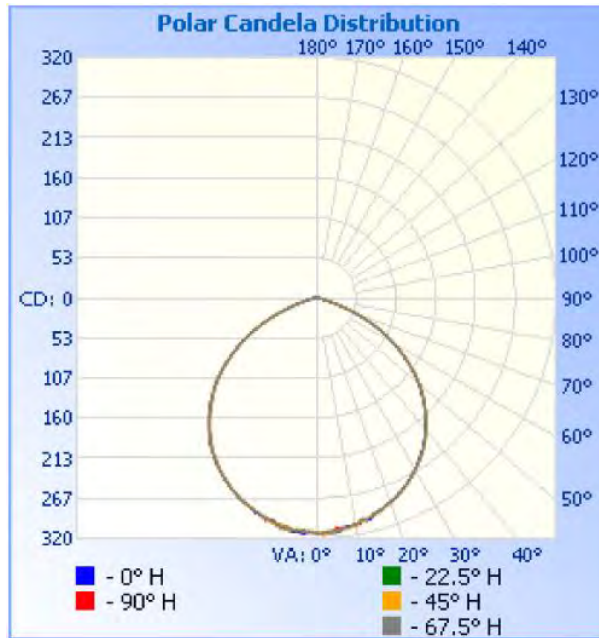

Isolux Plot

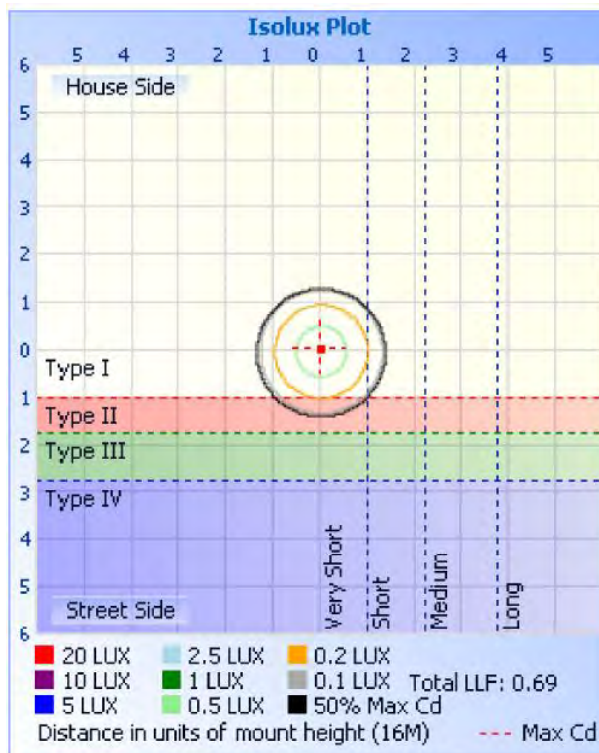



Goniophotometer Test (Cont'd)

Zonal Lumen Summary

Zonal Lumen Summary

Zone	Lumens	% Luminaire
0-30	241.0	30.5%
0-40	394.5	49.9%
0-60	681.6	86.2%
60-90	107.0	13.5%
70-100	27.5	3.5%
90-120	0.4	0%
0-90	788.6	99.8%
90-180	1.9	0.2%
0-180	790.4	100%

Lumens Per Zone

Lumens Per Zone

Zone	Lumens	% Total	Zone	Lumens	% Total
0-5	7.4	0.9%	90-95	0.1	0%
5-10	22.0	2.8%	95-100	0.1	0%
10-15	35.8	4.5%	100-105	0.1	0%
15-20	48.3	6.1%	105-110	0.1	0%
20-25	59.3	7.5%	110-115	0.1	0%
25-30	68.2	8.6%	115-120	0.1	0%
30-35	74.8	9.5%	120-125	0.1	0%
35-40	78.7	10.0%	125-130	0.1	0%
40-45	79.2	10.0%	130-135	0.1	0%
45-50	76.7	9.7%	135-140	0.1	0%
50-55	70.6	8.9%	140-145	0.2	0%
55-60	60.6	7.7%	145-150	0.2	0%
60-65	47.7	6.0%	150-155	0.2	0%
65-70	31.9	4.0%	155-160	0.2	0%
70-75	16.0	2.0%	160-165	0.1	0%
75-80	6.6	0.8%	165-170	0.1	0%
80-85	3.7	0.5%	170-175	0.1	0%
85-90	1.1	0.1%	175-180	0.0	0%



Color Angular Uniformity

Model No.	TSRC-4-JBX	Sample ID.	4651933
------------------	------------	-------------------	---------

Test Method

1. The sample was tested according to the IES LM-79-2008.
2. Photometric paramters were measured using a type C goniophotometer and software.
3. The ambient temperature shall be maintained at 25° C ± 1° C, measured at a point not more than 1 m from the sample and at the same height as the sample.
4. The sample was operated at 120 Volts AC, 60Hz. It was stabilized before measurement was made. Color spatial uniformity was calculated from the software taken at 1° vertical intervals and 90° horizontal intervals.

Test Results

Temperature (°C)	Voltage (Vac)	Frequency (Hz)	Current (A)	Power (W)	Maximum Δu'v'
24.6	120.03	60.00	0.0908	9.09	0.001

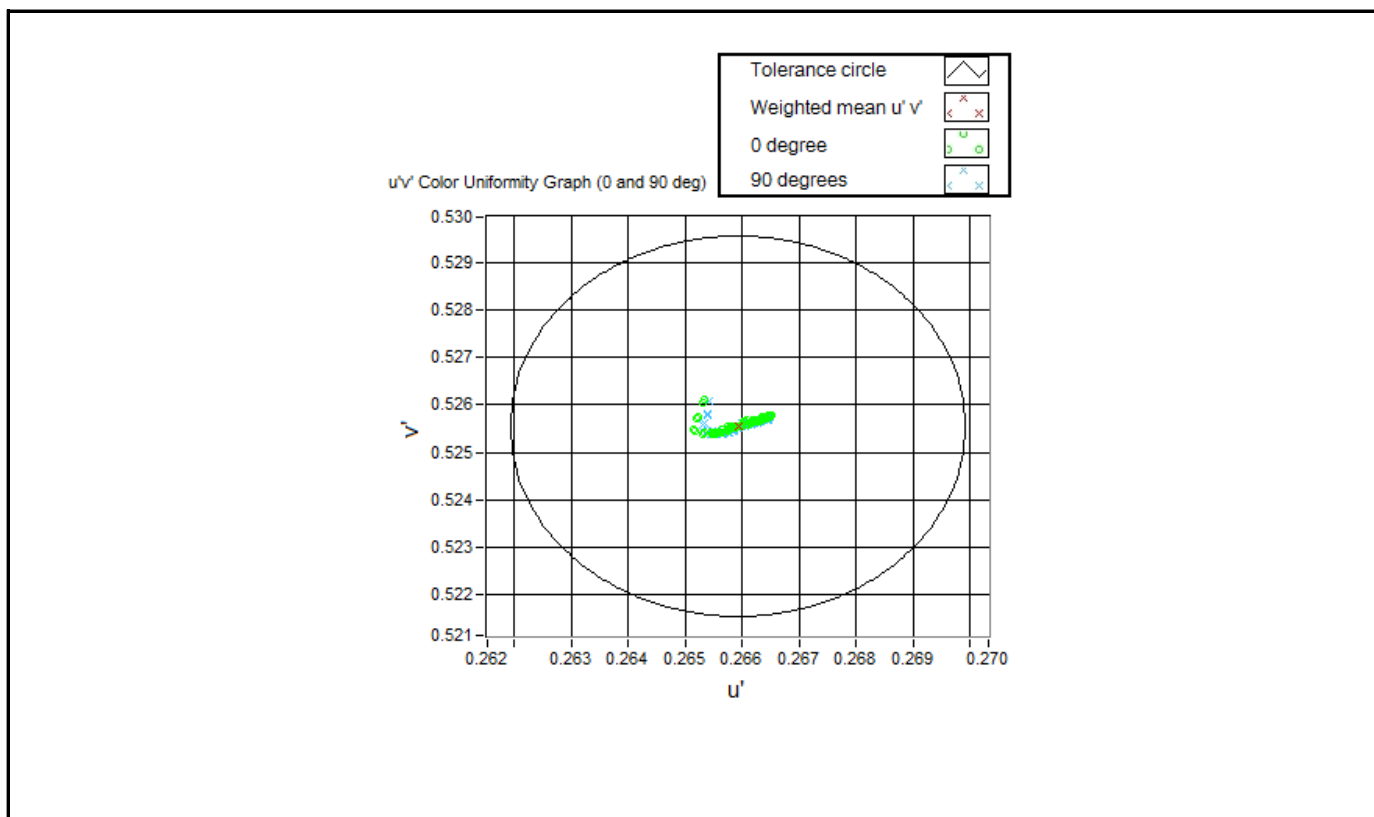



Source Start Time & Run-Up time

Model No.	TSRC-4-JBX	Sample ID.	4651933
------------------	------------	-------------------	---------

Test Method

1. The sample was tested according to ENERGY STAR Start Time Test and ENERGY STAR Run-Up Time Test for fluorescent luminaires only.
 2. Each test sample was operated in its designated orientation at rated input voltage in a $25 \pm 5^\circ\text{C}$ ambient. A photodetector is used to monitor the luminaire light output. Time was recorded when the sample was fully illuminated and reached 90% of stabilized lumen output.

Test Results

Temperature (°C)	Voltage (Vac)	Frequency (Hz)	Start Time (ms)	Run-Up time (s)
24.3	120.05	60.00	78.35	N/A

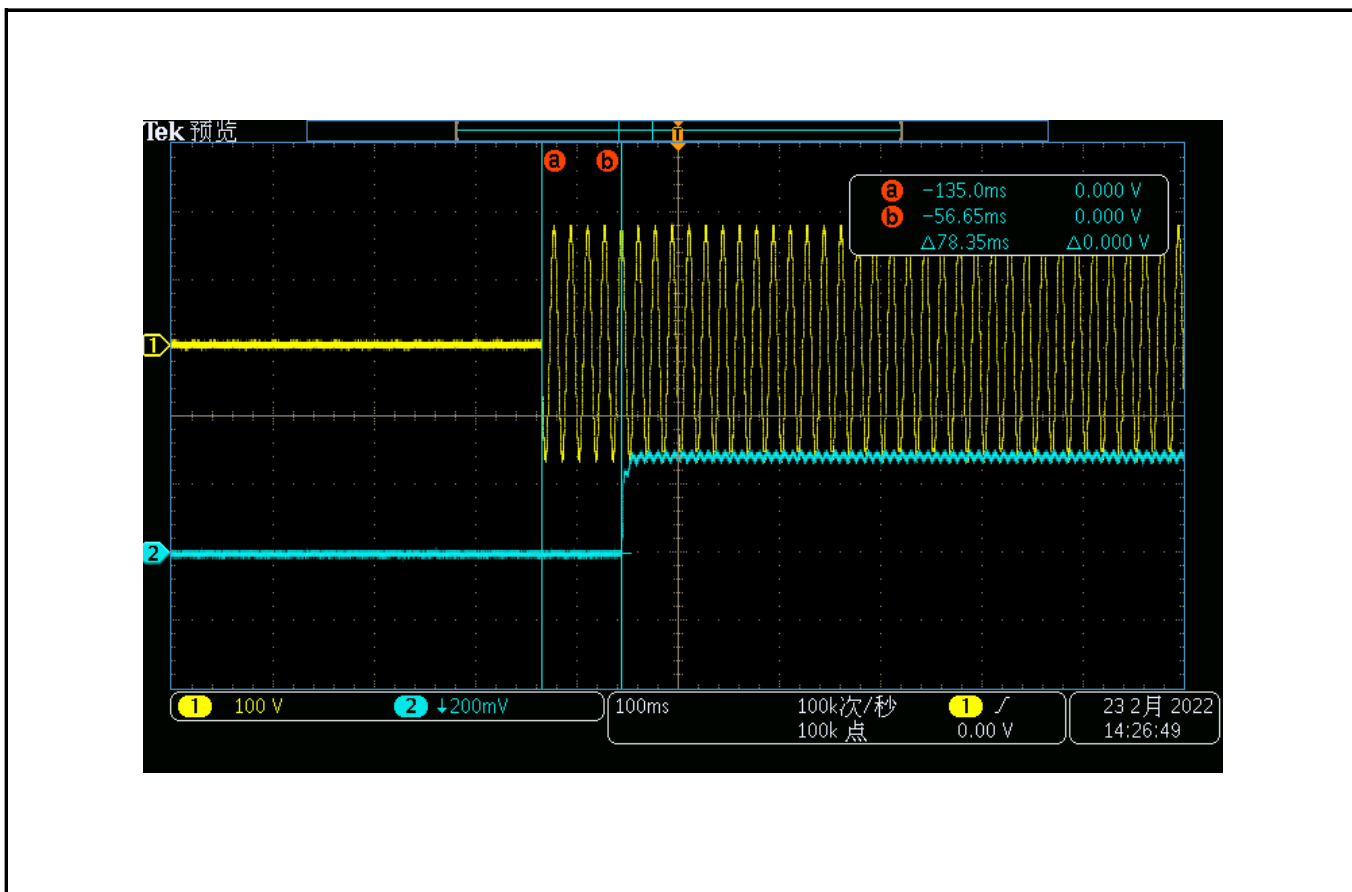



Operating Frequency Test

Model No.	TSRC-4-JBX	Sample ID.	4651933
------------------	------------	-------------------	---------

Test Method

1. The sample was tested according to ANSI C82.2-2002 for fluorescent luminaires.
2. Each test sample was operated at rated input voltage. Light output waveform shall be measured with a photodetector, transimpedance amplifier and oscilloscope. The AC ripple on the output DC line was measured and recorded by the oscilloscope according to Energy Star directions.

Test Results

Temperature (°C)	Voltage (Vac)	Frequency (Hz)	Operating Frequency (Hz)
24.3	120.06	60	120.2

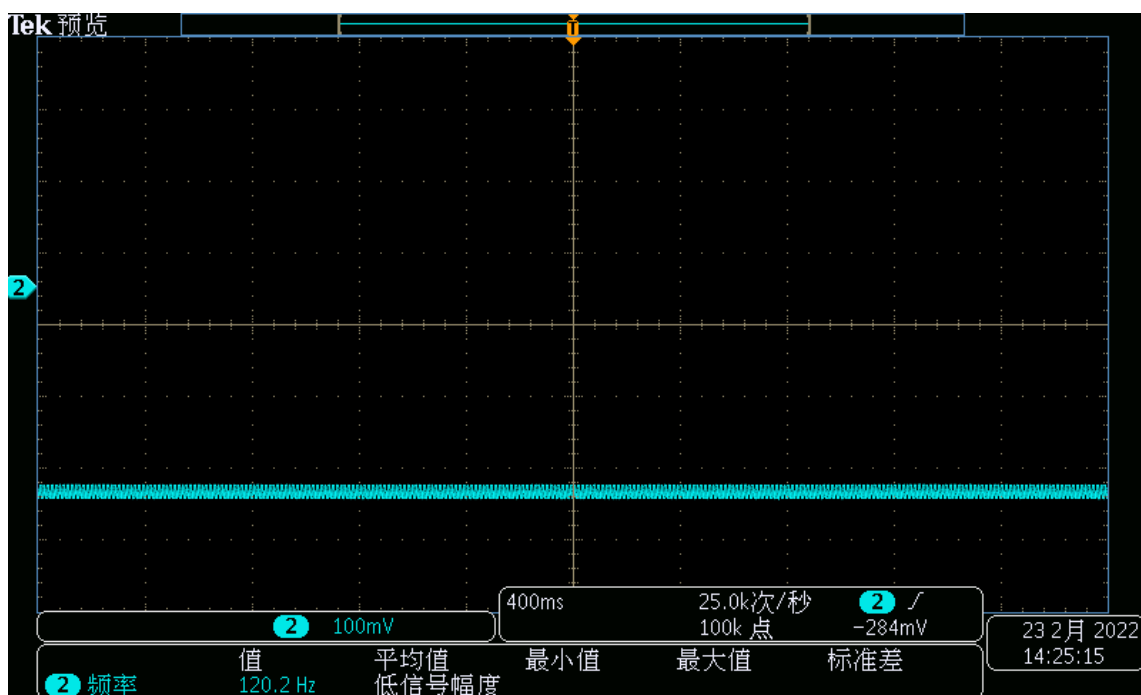



Transient Protection Test

Model No.	TSRC-4-JBX	Sample ID.	4651933
------------------	------------	-------------------	---------

Test Method

The transient protection tests at ambient temperature were performed on one sample. Each sample was operated at rated input voltage in the specific orientation during the tests. A Model PSVAGE8000 test system with an 100kHz Ring Wave Module and a Coupler/Decoupler Module was used to generate the 2500 volt ring wave transient strike across the luminaire contacts. Each wave consisted of a 0.5 microsecond rise time. Seven strikes were performed on each sample in accordance with ANSI/IEEE C62.41 (Category A): Recommended Practice on Surge Voltages in Low – Voltage AC Circuits.

Test Results

Temperature (°C)	Voltage (Vac)	Frequency (Hz)	After Test - Seven Strikes (Survival/Dead)
24.3	120.06	60	Survival



Flicker Test

Dimmer Information

Dimmable/Non-dimmable	Dimmer		Dimming Type	Prodcut Model No.	Sample ID	Temperature (°C)
dimmable	Manufacture	LUTRON	Continuous dimming	TSRC-4-JBX	4651933	24.3
	Model Number	DVSTV				

Test Method

1. The test was performed using a relative photometry method, according to NEMA 77-2017.
2. The measurement was taken one test sample combined with the dimmers. The sample was tested at the rated electrical parameter, and allowed to stabilize and verify by taking light output measurements every minute with interval 0.00004 seconds and equipment period 2 seconds, until consecutive measurements are no more than 0.5% apart.

Test Results

Test Condition		Input Voltage (V)	Input Current (A)	Power (W)	Power Factor	THDi (%)	Light Output (lx)	Pst	SVM
Dimmable	Full lighting output	119.98	0.0922	8.98	0.8119	71.39	709	0.236	1.425
Non-phase cut (Phase cut)	MaxLO	119.99	0.0944	9.53	0.8413	63.83	714	0.233	1.439
	50%	119.99	0.0506	5.00	0.8238	61.91	358	0.592	1.564
	MinLO	120.00	0.0209	0.91	0.3644	118.3	8.06	8.178	0.000
Maximum Reading								8.178	1.564



Dimming Test

Model No.	TSRC-4-JBX	Sample ID.	4651933
------------------	------------	-------------------	---------

Dimmer Information

Manufacture	LUTRON	Model Number	DVSTV
Rated for CFL / LED	N/A	Technology / Features	N/A

Test Method

1. The test was performed using a relative photometry method, according to ENERGY STAR Recommended Practice - Light Output on a Dimmer and ENERGY STAR® Recommended Practice - Noise.

2. The measurement was taken one test sample combined with the dimmers. The sample was tested at the rated electrical parameter, and allowed to stabilize and verify by taking light output measurements every minute, until consecutive measurements are no more than 0.5% apart.

3. The noise test shall be conducted on sample in the sound chamber with one microphone. The microphone was located in six position to get the peak noise.

Test Results

Temperature (°C)	Voltage (Vac)	Frequency (Hz)	Baseline Light Output (lx)		Maximum Light Output (lx)	Minimum Light Output (lx)
24.3	120.05	60	709		714	8.06
Ambient Sound (dBA)	Peak Noise at BLO (dBA)	Peak Noise at MaxLO (dBA)	Peak Noise at MinLO (dBA)	Position (degree)	Maximum Light Output Ratio (%)	Minimum Light Output Ratio (%)
18.0	18.1	18.1	18.1	0	100.71	1.14



In-Situ Temperature Measurement Test

Model No.	TSRC-4-JBX	Sample ID.	4651933
------------------	------------	-------------------	---------

Test Method

1. In-Situ Temperature Measurement Test is conducted according to the UL 1598-2008, Section 14.
 2. The testing was conducted in a room with ambient temperature of 25 °C ± 5 °C. The apparatus construction followed those described in UL1598-2008 for normal temperature testing. Thermocouples were placed on the LED package in the locations indicated by LM-80 report.
 Thermocouples were placed on the LED driver case in the locations specified by the manufacture if necessary. The temperature was recorded after the lamp was operated by 7.5 hours.
 3. The data and photos in LM-80 test report is provided by the customer/ The data and photos in driver specification is provided by the customer.

In-Situ Temperature Measurement Test Conditions

Temperature	Voltage (Vac)	Frequency (Hz)	Current (A)	Power (W)	Power Factor	Orientation
24.6	120.04	60.00	0.0920	9.06	0.8213	Horizontal

Test Results

Thermocouple Location	Measured Current (mA)	Temperature for Lighting source (°C)		LED Model Number	LM-80 Limit Current (mA)	LM-80 Limit Temp. (°C)
		Test result	Test result (Correct to 25 °C)			
TMP of LEDs	66	94.3	94.1	SL-ID2835FTA-31KAG	100	105
Ambient temperature	N/A	25.2	25.0			

Thermocouple Location	Temperature for LED driver (°C)		LED driver Model Number	LED Driver Tc Temp. (°C)
	Test result	Test result (Correct to 25 °C)		
TMP of LED drivers	91.6	91.4	TSRC4-10W-D	150
Ambient temperature	25.2	25.0		



In-Situ Temperature Measurement Test

Model No.	92150	Sample ID.	4776642
------------------	-------	-------------------	---------

Test Method

1. In-Situ Temperature Measurement Test is conducted according to the UL 1598-2008, Section 14.
 2. The testing was conducted in a room with ambient temperature of 25 °C ± 5 °C. The apparatus construction followed those described in UL1598-2008 for normal temperature testing. Thermocouples were placed on the LED package in the locations indicated by LM-80 report.
 Thermocouples were placed on the LED driver case in the locations specified by the manufacture if necessary. The temperature was recorded after the lamp was operated by 7.5 hours.
 3. The data and photos in LM-80 test report is provided by the customer/ The data and photos in driver specification is provided by the customer.

In-Situ Temperature Measurement Test Conditions

Temperature	Voltage (Vac)	Frequency (Hz)	Current (A)	Power (W)	Power Factor	Orientation
24.6	120.02	60.00	0.0918	9.06	0.8221	Horizontal

Test Results

Thermocouple Location	Measured Current (mA)	Temperature for Lighting source (°C)		LED Model Number	LM-80 Limit Current (mA)	LM-80 Limit Temp. (°C)
		Test result	Test result (Correct to 25 °C)			
TMP of LEDs	66	83.6	83.4	SL-ID2835FTA-31KAG	100	105
Ambient temperature	N/A	25.2	25.0			

Thermocouple Location	Temperature for LED driver (°C)		LED driver Model Number	LED Driver Tc Temp. (°C)
	Test result	Test result (Correct to 25 °C)		
TMP of LED drivers	76.8	76.6	TSRC4-10W-D	150
Ambient temperature	25.2	25.0		



In-Situ Temperature Measurement Test (Cont'd)

Test Photos for LEDs

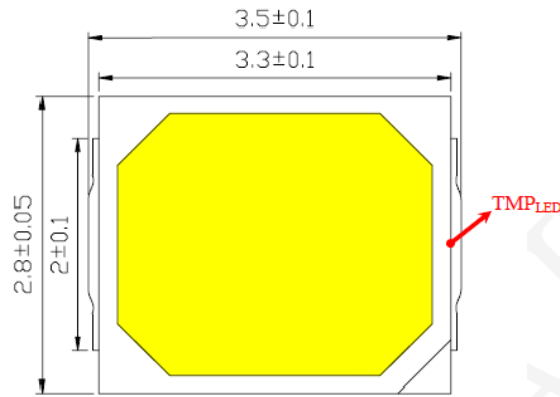
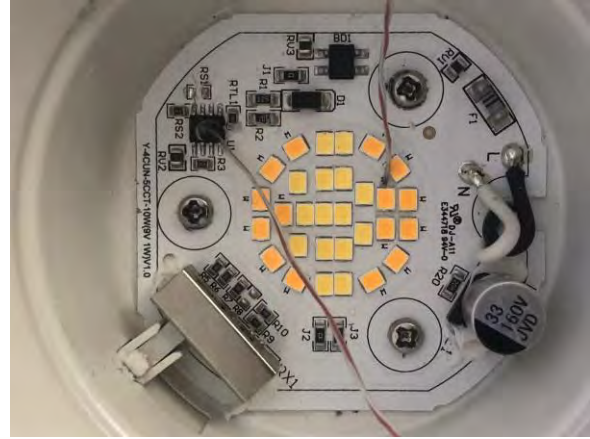
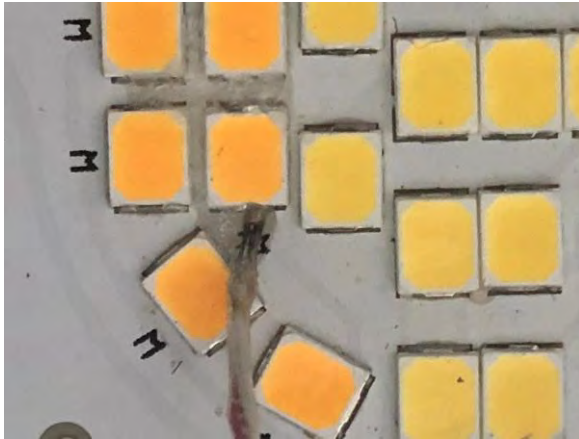

Test Photos for LED Drivers

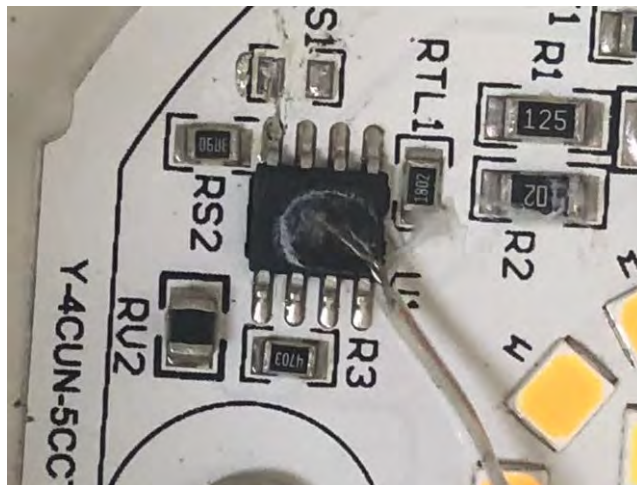



***** END OF REPORT. THIS PAGE INTENTIONALLY LEFT BLANK *****