



## TECHNICAL DATA SHEET

Superior Life® Enviro-Lume IR™ Halogen lamps use the latest infrared heat technology which allows the lamp to burn cooler, generating less heat and last longer than a standard halogen. This allows for maximum efficiency of the PAR lamps.

### FEATURES

- Uniform beam without hot spots
- Optimized lumen output
- Up to 40% longer life

### APPLICATION

Replaces standard 75W Halogen lamps, used for landscape and retail lighting.

# 96041

## PAR30 FLOOD LAMP

HALOGEN PAR

### PRODUCT DETAILS

ELECTRICAL	
Wattage	53W
Voltage	120V
LIGHTING PERFORMANCE	
Lumens	1020
Lumens Per Watt (Lm/W)	19
Color Temperature (CCT)	3000K
Dimmable Lighting Control	<i>Dimmable</i>
LIFESPAN	
Average Life (Hours)	4,000
Warranty (Years)	1
CONSTRUCTION	
Housing	Aluminum / Glass
Base / Power Supply	E26-Medium
Finish	Silver
CERTIFICATIONS	
☑ EISA Compliant (Meets US Min. Efficiency standards)	Yes

PACKAGING	
Master Carton	15pc / 10811768020301
Individual Box	811768020304
Country of Origin	China
HS Tariff	8539.21.4040
DIMENSIONS	
Dimensions (Inches)	3.5"(L) x 3.7"(DIA)

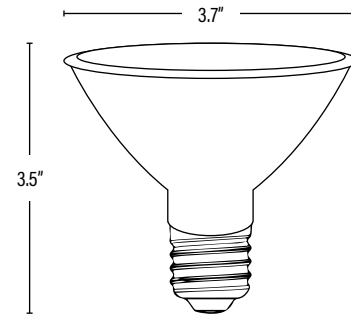

### ORDERING

ITEM#	DESCRIPTION	CASE
96041	53PAR30/FLOOD - ENVIRO-LUME IR™	15

Published lumens on products are approximate and may vary slightly.

[www.PQLighting.com](http://www.PQLighting.com)

© P.Q.L., INC. • 2285 WARD AVENUE • SIMI VALLEY, CA 93065 • 800.323.8107 • FAX: 877.619.7053

GO GREEN

0817