

# STEALTH™ AREA LIGHT

## INSTALLATION INSTRUCTIONS

**PLEASE USE A QUALIFIED ELECTRICIAN FOR INSTALLATION.** Read the instructions before installing or use of the luminaire.

### WARNING, CAUTIONS AND OPERATING INSTRUCTIONS

- To reduce the risk of death, personal injury or property damage from fire, electric shock, falling parts, cuts/abrasions, and other hazards read all warnings and instructions included with and on the fixture box and all fixture labels.
- Before installing, servicing, or performing routine maintenance upon this equipment, follow these general precautions.
- Commercial installation, service and maintenance of luminaires should be performed by a qualified licensed electrician.
- For The installation: If you are unsure about the installation or maintenance of the luminaires, consult a qualified licensed electrician and check your local electrical code.
- To prevent wiring damage or abrasion, do not expose wiring to edges of sheet metal or other sharp objects.
- Do not make or alter any open holes in an enclosure of wiring or electrical components during kit installation.
- Do not cover any part of the fixture; this can cause overheating.

### WARNING: RISK OF FIRE OR ELECTRICAL SHOCK

- Turn off electrical power at fuse or circuit breaker box before wiring fixture to the power supply.
- Turn off the power when you perform any maintenance.
- Verify that supply voltage is correct by comparing it with the luminaire label information.
- Make all electrical and grounded connections in accordance with the National Electrical Code and any applicable local code requirements.
- All wiring connections should be capped with UL approved wire connectors.

### CAUTION: RISK OF INJURY

- Avoid direct eye exposure to the light source while it is on.
- Account for small parts and destroy packing material, as these may be hazardous to children.
- Suitable for Wet locations.

## INSTALLATION

**WARNING DISCONNECT POWER BEFORE INSTALLING OR SERVICING.**

Product requires top-mounted shorting cap or optional twist-lock photocell installed to operate.

### TRUNNION MOUNTING (POLE)

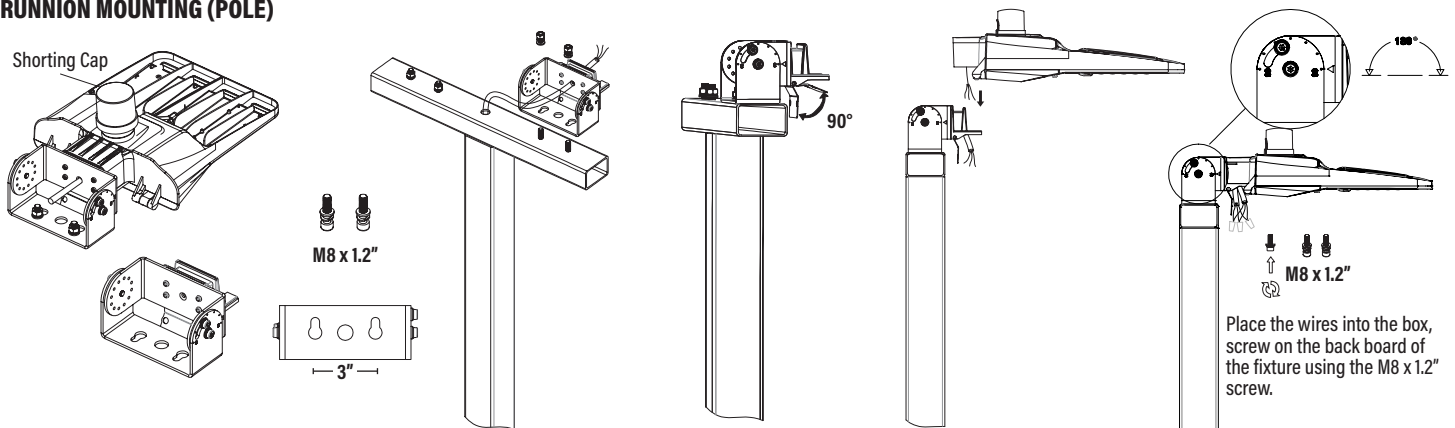

### TRUNNION MOUNTING (WALL)

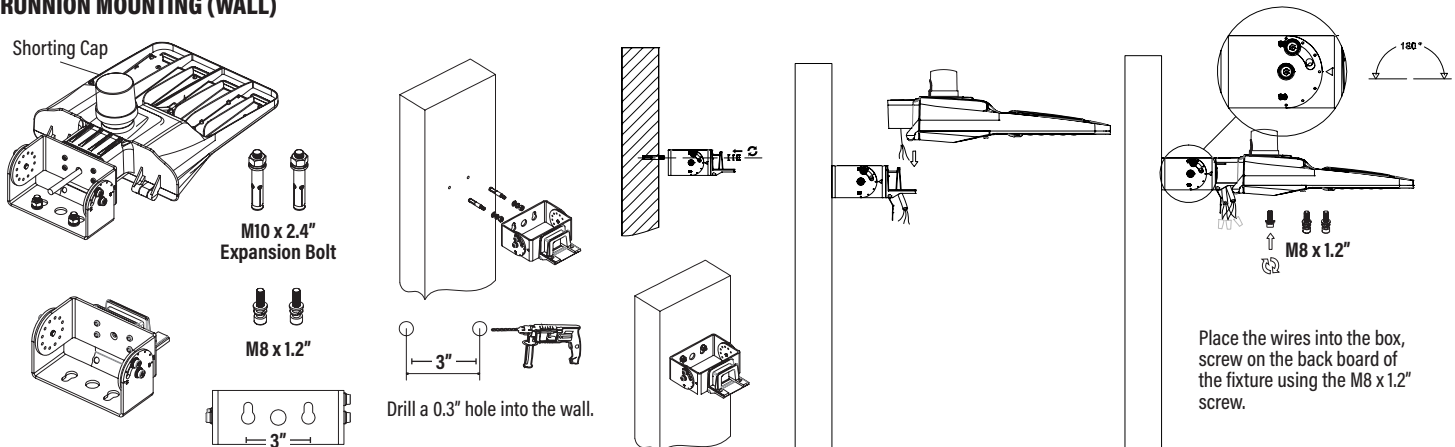

# STEALTH™ AREA LIGHT

## INSTALLATION INSTRUCTIONS

**PQL**  
PREMIUM QUALITY LIGHTING®

### INSTALLATION

**WARNING DISCONNECT POWER BEFORE INSTALLING OR SERVICING.**

Product requires top-mounted shorting cap or optional twist-lock photocell installed to operate.

#### SLIP FITTER MOUNTING

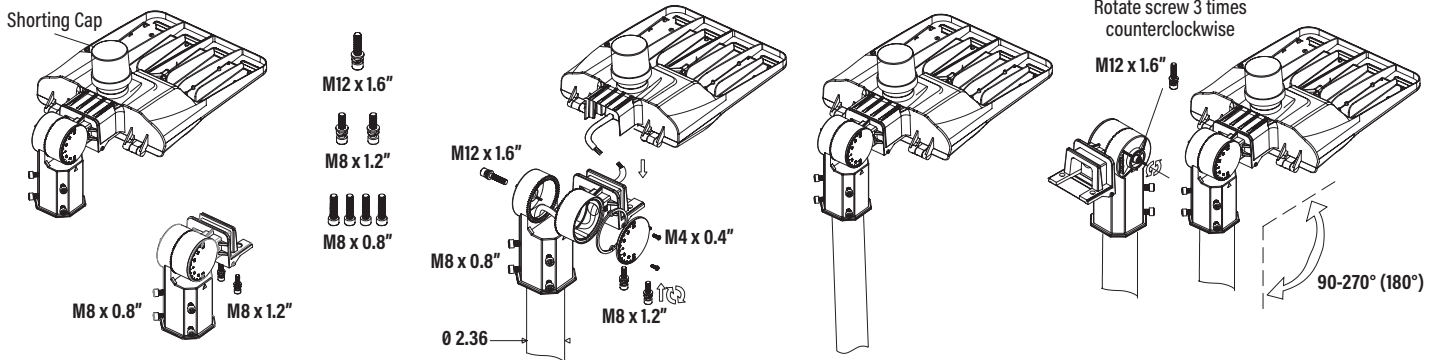

#### POLE MOUNTING

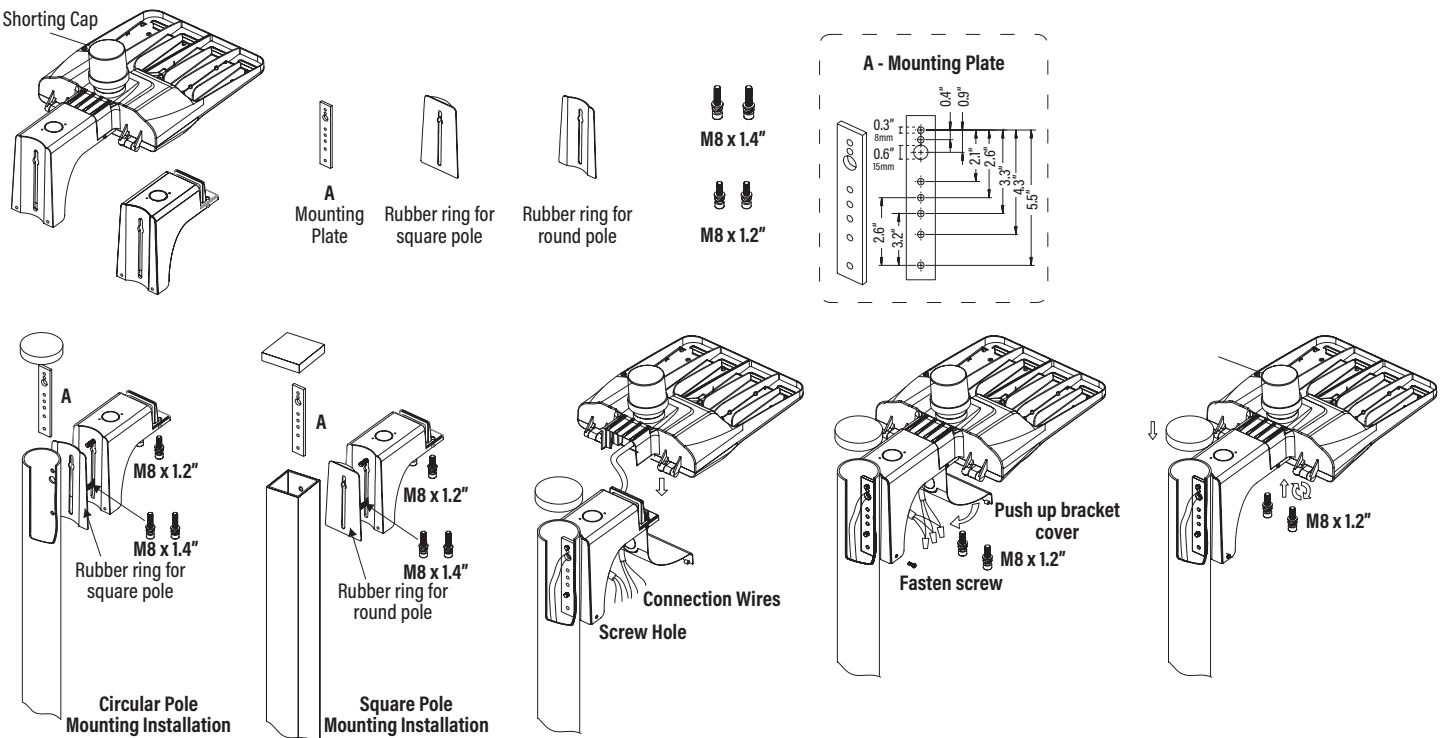

#### SENSOR INSTALLATION FOR POLE BRACKET

