



**SELECTABLE  
WATTAGE**

Item#: **BLW1UW22P140**  
**LED 2X2 POWER-SELECT™**  
**BACK-LIT PANEL**  
2X2 LUMINARIES FOR AMBIENT LIGHTING OF  
INTERIOR COMMERCIAL SPACES

**FEATURES**

Power-Select™ Backlit energy-efficient LED panels are like 3 fixtures in 1, and can provide the perfect balance of light in any application.

- Adjustable Wattage (3 settings)

**APPLICATION**

Ideal for retrofitting inefficient fixtures in malls, hospitals, airports, offices, lobbies and other residential and commercial applications.

**ELECTRICAL**

Wattage	20W / 25W / 30W
Voltage	120-277V
Current	30W @ 120V = 0.25A
Power Factor	0.9
Total Harmonic Distortion (THD)	--

**LIGHTING PERFORMANCE**

Lumens	2500 / 3125 / 3750
Lumens Per Watt (LPW)	125
Color Temperature (CCT)	4000K
Color Rendering (CRI)	80
R9 (Red Value)	--
Beam Angle	120°
Light Distribution	Type VS
BUG Rating (Backlight, Uplight, and Glare)	--
Dimmable Lighting Control	<i>Dimmable</i> 0-10V, Range 10% - 100%

**ENVIRONMENT**

Operating Temperature	-4° ~ 122°F
Suitable Location	<b>DAMP</b>
Ingress Protection Rating	IP40

**LIFESPAN**

Average Life (Hours)	50,000
Warranty (Years)	<b>5</b>

**COMPONENTS**

LED Light Source	--
Driver	--

**CONSTRUCTION**

Housing	Aluminum
Lens	Frosted
Base / Power Supply	Hard Wired
Finish	White

**QUALIFICATIONS**

Model Number	BLW1-U-W-22-P1-40K
Pending	

*Published lumens on LED products are approximate and may vary slightly. - Specifications are subject to change without notice.*

Item#: **BLW1UW22P140**  
**LED 2X2 POWER-SELECT™ BACK-LIT PANEL**



ITEM INFORMATION

**DIMENSIONS** (Inches)

Length	23.7"
Width	23.7"
Height	1.4"
Weight (Lbs)	--

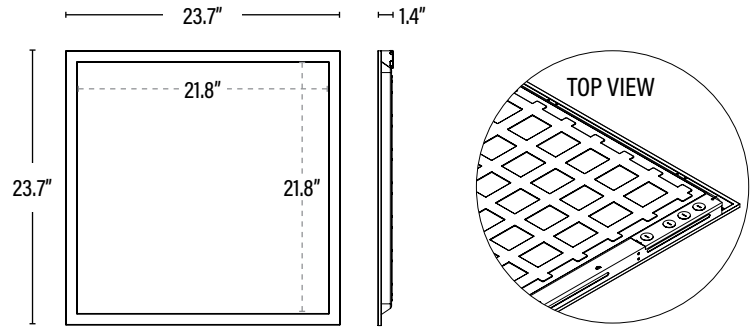

**SUPPORTING DOCUMENTS** (Grey = not available at this time.)

Product Sheet	VIEW
Install Instructions	VIEW
IES Download from Web Item	VIEW
LM79	VIEW
LM80	VIEW

**PACKAGING**

		UPC	DIMENSIONS (LxWxH)	GROSS WEIGHT (Lbs)
Master Carton	4	10811768023296	25.3" x 25.3" x 6.2"	--
Individual Item	1	811768023299	N/A	--
Country of Origin	China			
HS Tariff	--			

**ORDERING**

CODE	DESCRIPTION	CASE
BLW1UW22P140	BLP™ LED 2X2 POWER-SELECT™ PANEL/20-25-30W/40K/DIMM/120-277V	4

**ACCESSORIES**

55128	2X2 FLANGE KIT FOR PANEL & TROFFER/WHT	1
55531	2X2 SURFACE MOUNTED KIT FOR LED BACK-LIT PANEL/WHT	1
55445	5FT SUSPENDED CABLE MOUNTING KIT FOR LED PANEL	100
55446	10FT SUSPENDED CABLE MOUNTING KIT FOR LED PANEL	100
55706	EMERGENCY PACK FOR LED BLP PANEL 8W/90 MIN	10
55393	MOUNTING BRACKET AND WIRE BOXES FOR EMERGENCY PACK FOR LED 2X2 OR 2X4 PANEL	20
55697	DUAL COLOR TAPE TEST BUTTON AND ADAPTOR FOR EMERGENCY BATTERY TROFFER OR PANEL	400

**REPLACEMENT PARTS**

--	REPLACEMENT LED DRIVER	1
----	------------------------	---

**ADDITIONAL INFORMATION:**

- Default settings; 20W.
- The wattage may be adjusted by slide switches integrated into the driver, selection should be made prior to installation.

